



**WIT 29.9-50K-XHU Hybrid Inverter  
User Manual**

# Contents

<b>1</b>	<b>Notes on this manual</b>	<b>1</b>
1.1	Introduction	1
1.2	Target Group	1
1.3	Product Range	1
<b>2</b>	<b>Safety Precautions</b>	<b>2</b>
2.1	Safety Instructions	2
2.2	Symbol Conventions	4
2.3	Label Description	5
<b>3</b>	<b>Product Description</b>	<b>6</b>
3.1	Overview	6
3.2	Basic Data	8
3.3	Nameplate	10
3.4	Operating Principle of WIT 29.9-50K-XHU	11
3.5	Storing the WIT Inverter	12
3.6	Supported Grid Types	12
3.7	AFCI Function	12
3.7.1	AFCI Function Description	12
3.7.2	Clearing the alarm	13
3.8	Anti-PID Function	14
<b>4</b>	<b>Inspection upon delivery</b>	<b>15</b>
<b>5</b>	<b>Installation</b>	<b>16</b>
5.1	Basic Installation Requirements	16
5.2	Installation Environment Requirements	17
5.3	Moving the WIT Inverter	19
5.4	Wall Mount Bracket Installation	20
5.5	Installing the Inverter	21
<b>6</b>	<b>Electrical Connections</b>	<b>23</b>
6.1	Connecting the Ground Cables	30
6.2	Connection on the AC Side	31
6.3	DConnection on the PV Side	35

6.4 Connection on the Battery Side .....	37
6.4.1 Connecting the Main Power Cable of the Battery .....	38
6.4.2 Connecting the Battery BMS-AC Terminal.....	40
6.5 Connecting Communication Cables .....	41
6.5.1 COM1 Connection.....	41
6.5.2 COM2 Connection .....	46
6.5.3 USB connection.....	48
6.6 Post-installation Checks .....	49
<b>7 Commissioning .....</b>	<b>51</b>
7.1 Commissioning the WIT Inverter.....	51
7.1.1 Set the Communication Address .....	51
7.1.2 Set the Time and Date .....	51
7.2 Mode of operation.....	52
7.2.1 Waiting Mode.....	52
7.2.2 Operating Mode .....	53
7.2.3 Fault Mode .....	58
7.2.4 Shutdown Mode .....	58
7.3 LED and OLED Display Panel.....	59
<b>8 Monitoring .....</b>	<b>62</b>
8.1 Remote Monitoring .....	62
8.1.1 Remote Monitoring on the APP (ShinePhone) .....	62
8.1.2 Remote Monitoring on the ShineServer Webpage.....	79
<b>9 System Maintenance.....</b>	<b>106</b>
9.1 Routine Maintenance.....	106
9.1.1 Clean the Chassis.....	106
9.1.2 Fan Maintenance.....	106
9.2 Troubleshooting .....	108
9.2.1 Warning .....	108
9.2.2 Error.....	113
<b>10 Product Specifications .....</b>	<b>119</b>

<b>11 Decommissioning the WIT Inverter .....</b>	<b>123</b>
<b>12 Warranty .....</b>	<b>124</b>
12.1 Conditions .....	124
12.2 Disclaimer .....	124
<b>13 Contact Us .....</b>	<b>125</b>

# 1 Notes on this manual

## 1.1 Introduction

This manual is intended to introduce the WIT 29.9-50K-XHU Hybrid Inverters manufactured by Shenzhen Growatt New Energy Co., Ltd. (hereinafter referred to as Growatt) in terms of their installation, operation, commissioning, maintenance and troubleshooting. Please read this manual carefully before using the product, and keep it in a convenient place for further reference. The content of this manual is continually reviewed and amended, where necessary. Growatt reserves the right to make changes to the material at any time and without notice.

**Note:**

“WIT” refers to the product name. “29.9-50K” refers to the power range.

## 1.2 Target Group

This document is intended for qualified technicians. Only qualified and well-trained technicians are allowed to install and operate the WIT inverter. Should any questions arise during installation, you can visit [en.growatt.com](http://en.growatt.com) to leave a message, or call our 24-hour service hotline at +86 755 2747 1942.

## 1.3 Product Range

WIT 29.9-50K-XHU (AC 380V/400V) inverters offering five power options: 29.9kW, 30kW, 36kW, 40kW, and 50kW. In total, there are 5 products available in this series. This manual is valid for the following models:

Table 1.1 WIT 29.9-50K-XHU series model introduction

WIT 29.9K-XHU	3-Phase Hybrid Inverter with UPS function
WIT 30K-XHU	
WIT 36K-XHU	
WIT 40K-XHU	
WIT 50K-XHU	

# Safety Precautions 2



## 2.1 Safety Instructions

- 1) Please read this manual carefully before installation. Damages caused by failure to follow the instructions in the manual are beyond the warranty scope.
- 2) Only qualified and trained electrical technicians are allowed to perform operations on the WIT Inverter.
- 3) During installation, please do not touch other parts inside the equipment other than the wiring terminals.
- 4) Ensure that all electrical connections comply with local electrical standards.
- 5) Only designated personnel are permitted to perform maintenance on the inverter.
- 6) Before operating the WIT Inverter in on-grid mode, ensure that you have obtained any permission needed from the local grid operator.



### Transportation:

 <b>WARNING</b>	<ul style="list-style-type: none"><li>• Risk of injury when lifting the WIT Inverter, or injury caused by a falling inverter as it is heavy. Please transport and lift the inverter carefully.</li></ul>
---	--



### Installation:

 <b>NOTICE</b>	<ul style="list-style-type: none"><li>• Please read this manual carefully before installation. Damages caused by failure to observe instructions specified in this manual are not covered under any warranty.</li></ul>
 <b>DANGER</b>	<ul style="list-style-type: none"><li>• Do not connect any cables before installation.</li></ul>
 <b>WARNING</b>	<ul style="list-style-type: none"><li>• Please observe the installation instructions specified in this manual, including the installation environment and clearance requirements.</li><li>• Install the WIT Inverter in a dry and well-ventilated location; otherwise, performance de-rate may be initiated due to excessive temperature.</li><li>• Please read the installation instructions and safety precautions carefully before installation.</li></ul>



### Electrical Connections:

 <p><b>DANGER</b></p>	<ul style="list-style-type: none"><li>• Before connecting cables, ensure that the DC switches of the WIT Inverter are OFF, and turn off the switch and breaker on the AC side and the battery side. Otherwise, high voltages may cause severe injuries.</li><li>• It must be operated by qualified and trained electrical technicians. Technicians should observe instructions in this manual and local regulations.</li><li>• High voltages may cause electric shocks and serious injury. Please do not touch the WIT Inverter in operation.</li><li>• Do not install the inverter in potentially explosive and flammable atmospheres.</li></ul>
 <p><b>WARNING</b></p>	<ul style="list-style-type: none"><li>• Each WIT Inverter must be equipped with an AC circuit breaker. Multiple WIT Inverters cannot connect to the same AC circuit breaker.</li><li>• Do not connect the load between the WIT Inverter and the circuit breaker.</li><li>• If the cable is thick, do not shake the cable terminals after tightening them. Otherwise, the loose connection may cause overheating and device damage. Ensure that the terminals are properly connected before starting the WIT Inverter.</li><li>• Ensure the correct polarity of the terminals before connecting the PV array to the WIT Inverter.</li></ul>





### Maintenance and replacement:

 <p><b>DANGER</b></p>	<ul style="list-style-type: none"><li>• It must be operated by qualified and trained electrical technicians. Technicians should observe instructions in this manual and local regulations.</li><li>• After turning off the DC switches and the AC breakers, wait for at least five minutes before performing any operations to avoid risks.</li><li>• When the OLED screen indicates “PV Isolation low” , do not touch the chassis as a ground fault may have been detected.</li><li>• Beware of high voltages which may cause electric shocks.</li></ul>
 <p><b>WARNING</b></p>	<ul style="list-style-type: none"><li>• To ensure good dissipation, clean the fan regularly.</li><li>• Do not use the air pump to clean the fan. Otherwise, the fan may be damaged.</li></ul>







**Others:**

	<ul style="list-style-type: none"><li>• Upon receiving the product, check if the contents are intact and complete. If any damage is found or any component is missing, please contact your distributor.</li></ul>
 <b>WARNING</b>	<ul style="list-style-type: none"><li>• The maximum PV input voltage cannot exceed 1100V. The battery input voltage cannot exceed 900V.</li><li>• For the WIT Inverter that will not be put into operation in the future, you should properly dispose of them by yourself.</li></ul>

## 2.2 Symbol Conventions

Symbol	Description
 <b>DANGER</b>	<b>DANGER</b> indicates a hazard with a high level of risk which, if not avoided, will result in death or serious injury.
 <b>WARNING</b>	<b>WARNING</b> indicates a potentially hazardous situation which, if not avoided, could result in death or serious injury.
 <b>CAUTION</b>	<b>CAUTION</b> indicates a hazard with potential risk which, if not avoided, could result in minor or moderate injury.
 <b>NOTICE</b>	<b>NOTICE</b> indicates that under certain circumstances, improper operations could result in property damage.
	<b>Remind</b> operators to check the instructions before installing or operating the WIT Inverter.

## 2.3 Label Description

Symbol	Name	Meaning
	High voltage	High voltages exist after the WIT Inverter is powered on. Only qualified and trained electrical technicians are allowed to perform operations.
	Burn warning	Do not touch a running inverter because it generates high temperatures on the shell.
	Grounding	Indicates the position for connecting the PE cable.
	Delay discharge mark	Residual voltage exists after the WIT Inverter is powered off. It takes 5 minutes to discharge to the safe voltage.
	Refer to the manual	Remind operators to refer to the manual before installing and operating the WIT Inverter.
	DC	Direct Current.
	AC	Alternating Current.

# Product Description 3



**NOTICE**

The front view and the bottom view of all models are identical.

## 3.1 Overview

Front view:

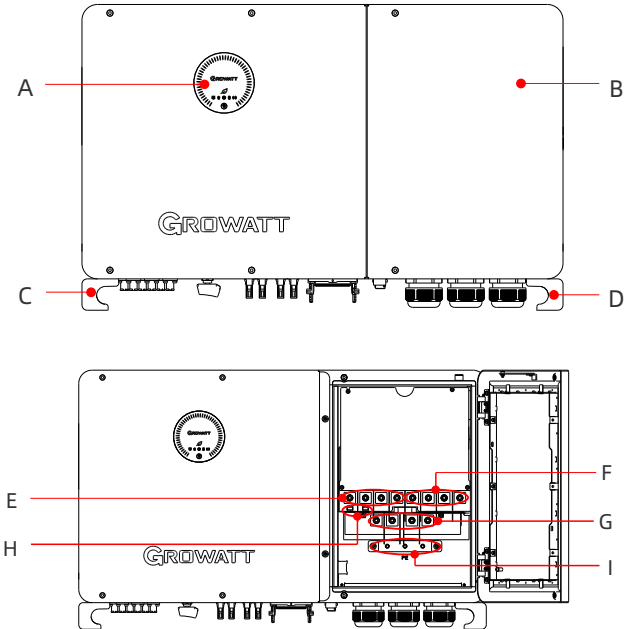

Fig 3.1 Front view

Bottom view:

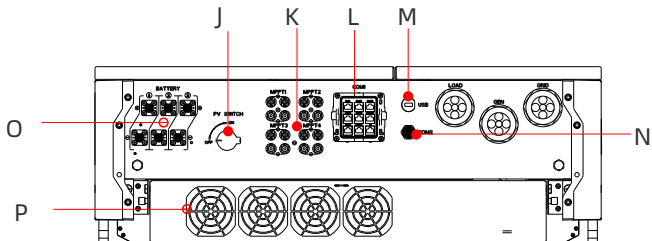

Fig 3.2 Bottom view

Left view:

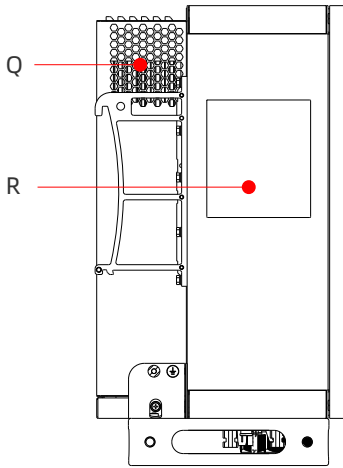

Fig 3.3 Left view of WIT 29.9-50K-XHU

Right view:

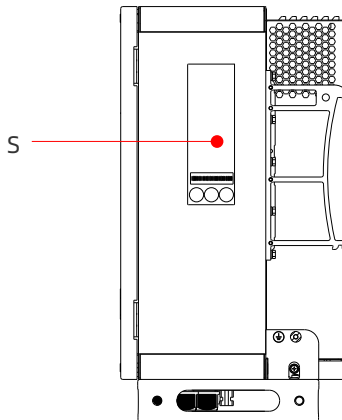

Fig 3.4 Right view of WIT 29.9-50K-XHU

Table 3.1 Component description

No.	Description	No.	Description
A	Display	B	Right cover plate
C	Left corner guard	D	Right corner guard
E	Load wiring terminal	F	Power grid connection terminal
G	Generator connection terminal	H	Battery power supply terminal (BMS AC)
I	Grounding bar	J	PV Switch
K	PV terminal	L	COM1 (RJ45*9)
M	USB interface	N	COM2 (4-pin terminal)
O	Battery terminal	P	Fan
Q	Heat sink	R	Indicator description label
S	Nameplate		

## 3.2 Basic Data

Table 3.2 Dimensions and weight

	Model	Size (mm)			Weight (kg)
		Height	Width	Depth	
The WIT Inverter without package	WIT 29.9-50K-XHU	585	920	320	92kg
The WIT Inverter with package	WIT 29.9-50K-XHU	500	1080	765	106kg

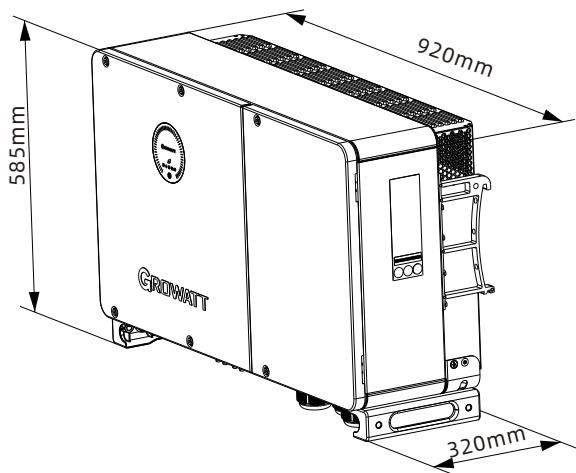

Fig 3.5

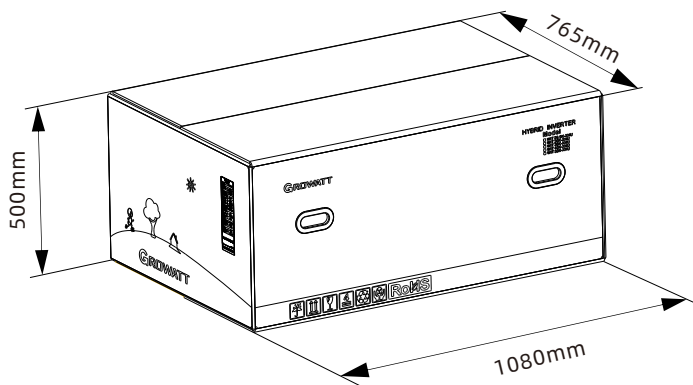

Fig 3.6

### 3.3 Nameplate

The figure below shows the nameplate of WIT 50K-XHU as an example. The nameplate figure is for reference only. The actual nameplate prevails. For the specifications, please refer to Section 10 Product Specifications.

# GROWATT

Hybrid Inverter  
WIT 50K-XHU

---

## PV Data

Max. PV voltage	1100 d.c.V
PV voltage range	180-1000 d.c.V
PV Isc	50 d.c.A*4
Max. input current	40 d.c.A*4

---

## AC Data

Nominal input/output power	100/50 kW
Max. input/output apparent power	110/55 kVA
Nominal voltage	3W/N/PE 230/400 a.c.V
Max. input/output current	166.7/83.3 a.c.A
Nominal frequency	50/60 Hz
Power factor range	1 leading~1 lagging
Max. continuous AC passthrough	200 a.c.A

---

## Load Data

Nominal AC output power	50 kW
Nominal AC output voltage	230/400 a.c.V
Nominal AC output frequency	50/60 Hz
Max. continuous GEN passthrough	200 a.c.A

---

## Battery Data

Battery voltage range	200-900 d.c.V
Max. charging and discharging current	55 d.c.A*3
Type of battery	Lithium-ion

---

## General Data

Safety level	Class I
Ingress protection	IP66
Operation ambient temperature	-30°C - +60°C

Integrated with AFCI

Download  
Manual

Made in China

Fig 3.7 Nameplate

### 3. 4 Operating Principle of WIT 29.9-50K-XHU

- 1> The hybrid inverter receives DC inputs from PV strings which go through the MPPT routes. The DC power is then converted into AC power through the inverter circuit to power the loads and feed power into the grid;
- 2> The PV strings can supply power to charge the battery through the MPPT routes;
- 3> Convert battery power to AC power supplies for the loads and feeding to the grid;
- 4> Charge the battery from the grid through a rectifier circuit;
- 5> Convert the DC power from PV strings and the battery power into AC power through the inverter circuit to power critical loads.
- 6> When the GEN port is connected to the generator and set to the GEN mode, the generator can supply power to the loads or charge the battery.
- 7> When the GEN port is connected to loads and set to "Smart Load" mode, during on-grid operation, it will supply grid power to the loads connected via the GEN port; during off-grid operation, the power supply to smart loads will be cut off.
- 8> When the GEN port is connected to the on-grid inverter and set to "AC Couple" mode, during on-grid operation, the on-grid inverter will be connected to the grid and output power; during off-grid operation, the on-grid inverter will remain connected and generating power together with the WIT inverter.

**NOTE:** WIT 29.9-50K-XHU models have 4 MPPT routes.

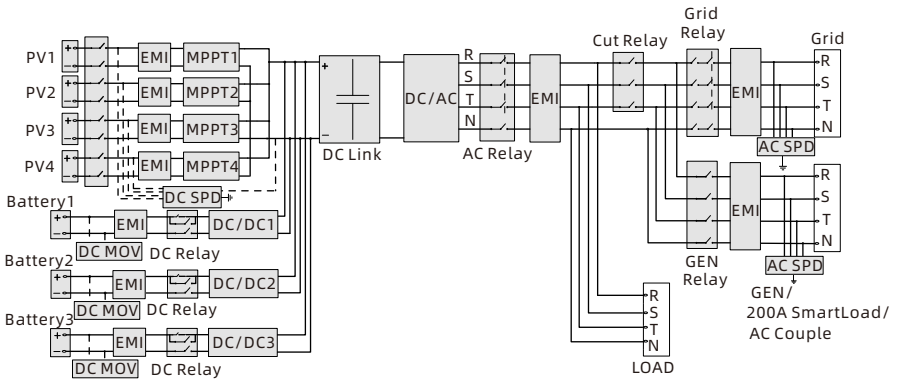

Fig 3.8 WIT 29.9-50K-XHU Grid-connected conceptual diagram

### 3.5 Storing the WIT Inverter

- 1> Put the WIT Inverter in the original package and place it in a dry and well-ventilated place.
- 2> Keep the storage temperature from  $-40^{\circ}\text{C}$  to  $+70^{\circ}\text{C}$  and the humidity from 0%-95% RH.
- 3> A maximum of three WIT Inverters can be stacked. Do not stack the inverters without package.
- 4> If the WIT Inverter has been long-term stored, inspections and tests should be conducted by qualified personnel before installation.



Wrong time and date may occur if the WIT Inverter has been stored for over one month. Fix the time and date before connecting the inverter to the grid. For details, see 7.1 Commissioning the WIT Inverter.

### 3.6 Supported Grid Types

Grid connection modes for WIT 29.9-50K-XHU Hybrid Inverters are shown in Fig 3.9.

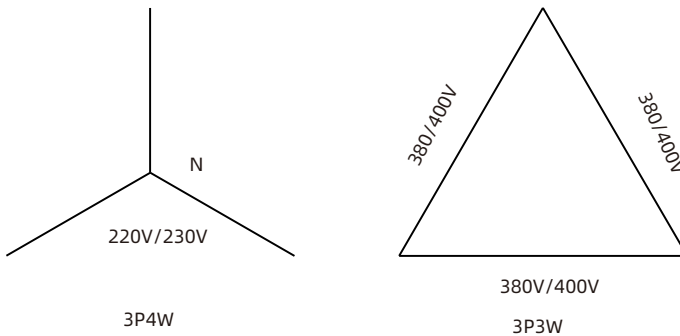

Fig 3.9 380V/400V system (type Y/ $\Delta$ )

### 3.7 AFCI Function

#### 3.7.1 AFCI function Description

An AFCI, or Arc-Fault Circuit Interrupter, is a solution designed to detect and mitigate the risk of electrical arcing in a photovoltaic (PV) system, supported by intelligent arc detection algorithm. Arcing can occur when there is a high voltage breakdown in the electrical insulation or when conductive materials come into contact with each other. This can pose a fire hazard and damage the system components. The AFCI continuously monitors the system for potential arc faults and, if detected, interrupts the circuit to prevent a fire or other damage. AFCIs are required by the National Electrical Code (NEC) in certain parts of a PV system, such as the DC side of the inverter, to improve safety and reduce the risk of fires.

**NOTE:**

1. The AFCI Function of the WIT Inverter is disabled by default. If you want to enable the AFCI, please contact Growatt support.
2. Do not connect the Maximum Power Point Trackers (MPPTs) on the DC side in parallel as it might trigger the AFCI mistakenly.

**3.7.2 Clearing the Alarm**

In the event that the WIT Inverter reports “AFCI Fault” and the PV indicator turns red, an arc fault might have been detected. Please perform the following steps to clear the alarm.

**Step 1:** Disconnect the WIT inverter from all power sources. Turn off the battery switch and the AC output circuit breaker, then turn the DC switches to the OFF position. Wait until the error message disappears.

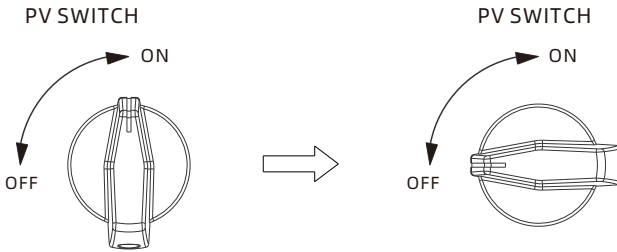

Fig 3.10

**Step 2:** Troubleshooting. Check if the open-circuit of all PV strings are within the permissible range.

**Step 3:** After the fault is cleared, restart the inverter. Turn on the battery switch and the AC breaker, and turn the DC switch to the ON position. Wait until the system is working properly.

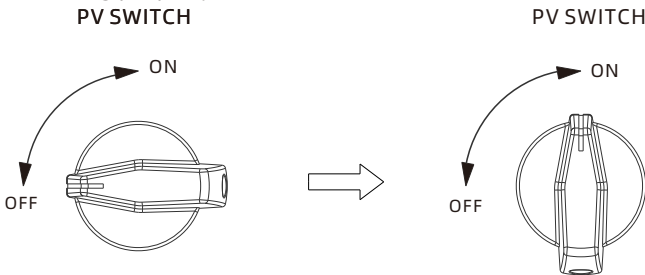

Fig 3.11

If the WIT Inverter passes the AFCI self-test, it will work in the normal mode and the PV indicator will be green. If it fails, the inverter will report “Error 425” . In this case, please reboot the system and perform Step 1 to Step 3. If it failed again, please disconnect all power sources and contact Growatt support.

### **3.8 Anti-PID Function**

PID (Potential Induced Degradation) typically occurs in PV systems where there is a voltage potential between the solar cells and the grounded frame or other conductive elements of the system. This potential difference, combined with high humidity and temperature, can lead to leakage currents that degrade the performance of the solar modules over time. The Anti-PID function integrated in Growatt inverters can effectively reverse the PID effect by applying DC voltage to the PV modules during nighttime, enhancing solar energy harvest and performance.

# 4 Inspection upon delivery

## Unpacking and inspection

- 1> Before unpacking the WIT Inverter, check the shipping box for any externally visible damage. If any damage is found, contact the shipping company as soon as possible.
- 2> After unpacking the WIT Inverter, check if the scope of delivery is intact and complete. If any damage is found or any component is missing, contact your distributor.

Check the following items:

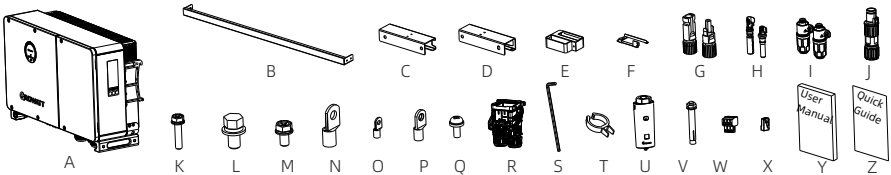

Fig 4.1 Packing list of WIT 50K-XHU

Table 4.1 Packing list

No.	Description	Quantity	No.	Description	Quantity
A	The WIT Inverter	1	P	SC35-8 AC terminal	4
B/C/D	Wall mount kit	1/1/1	Q	M4*12 screw	4
E/F	Battery terminal anti-dismantle element	1/1	R	COM1 waterproof cover	1
G	PV+(-) connector	8(8)	S	Allen wrench	1
H	PV+(-) metal contact	8(8)	T	PV connector disconnect tool	1
I	Battery +(-) terminal	3(3)	U	ShineWiLan-X2	1
J	COM2 terminal	1	V	M10*90 expansion bolt	4
K	M6*28 screw	2	W	BMS-AC terminal	4
L	M8*20 screw	12	X	RJ45	8
M	M6*12 screw	5	Y	User Manual	1
N	SC50-8 AC terminal	8	Z	Quick Guide	1
O	SC25-6 PE terminal	3			

**NOTE:** Sturdy and durable though the packing carton is, please carry and handle it with caution.

# Installation 5

## 5.1 Basic Installation Requirements

- A. The installation location must be suitable for WIT's weight for a long period time. (Refer to Table 3.2 for the weight of the WIT Inverter).
- B. Ensure that the installation position is suitable for the dimensions of the WIT Inverter.
- C. Do not install the WIT Inverter in areas with flammable or non heat-resistant materials.
- D. The WIT Inverter is protected to IP66 and can be installed indoors or outdoors.
- E. Do not expose the WIT Inverter to direct sunlight. Otherwise, excessive temperature may lead to power reduction.
- F. Keep the humidity at 0% to 95% RH.
- G. Keep the ambient temperature at  $-30^{\circ}\text{C}$  to  $60^{\circ}\text{C}$ .
- H. The WIT inverter can be installed vertically or backward tilted. Please refer to the figures below:

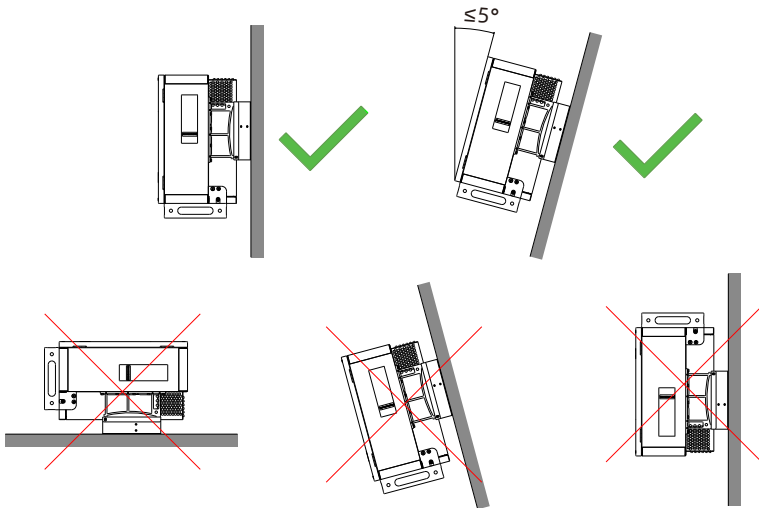

Fig 5.1

I. Reserve enough clearance around the WIT Inverter to ensure sufficient space for heat dissipation and operation. Leave a clearance of 0.6 m on both sides, approximate 0.6 m above and below the WIT Inverter, and 1 m in front of the inverter.

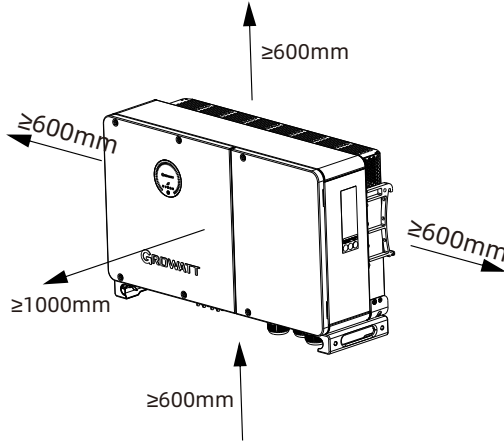

Fig 5.2

J. Keep the WIT Inverter away from strong interference sources.

K. Ensure that the WIT Inverter is not accessible to children.

## 5.2 Installation Environment Requirements

A. Though the WIT Inverter is protected to IP66, do not expose it to direct sunlight, rain and snow. Please refer to the figures below:



Fig 5.3

B. To reduce the de-rate performance of the inverter and extend inverter's life span, we strongly recommend you install an awning. For the distance between an awning and inverter, please refer to following figure.

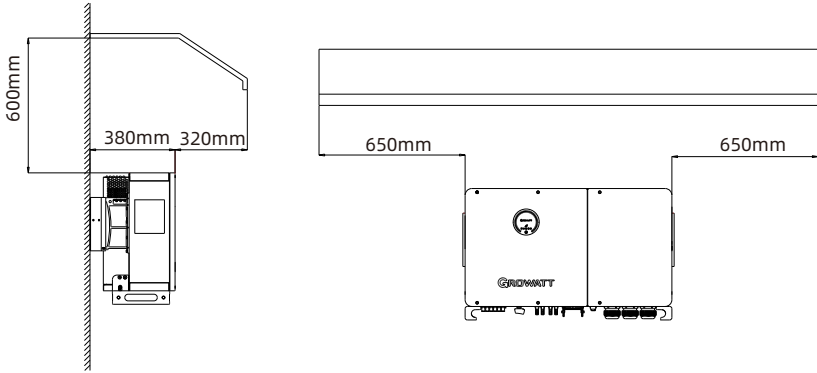
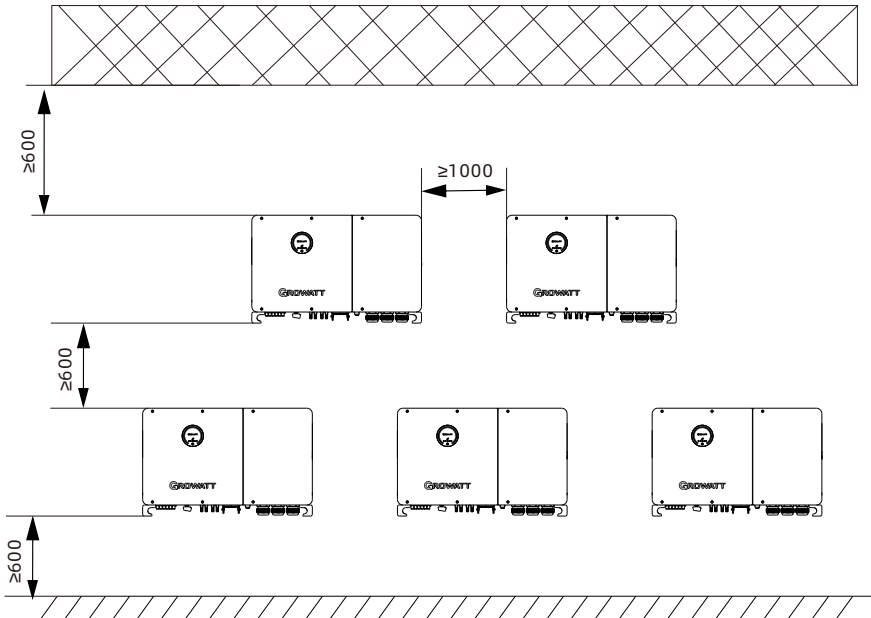

Fig 5.4

C. When you install multiple WIT inverters on one surface, inverters should be installed as following drawing. (Choose one of the two options below).

unit: mm



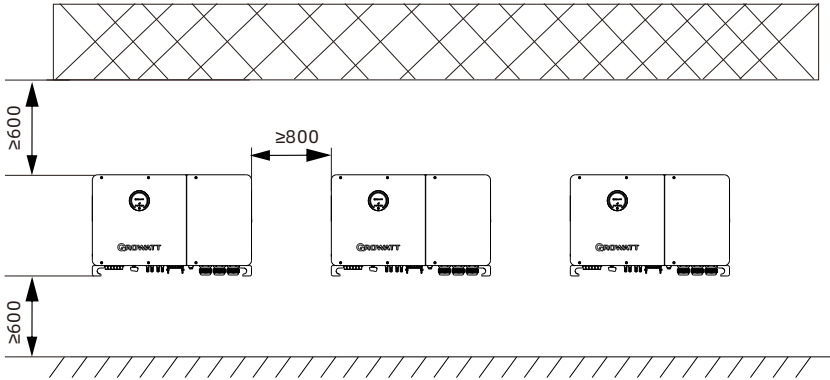

Fig 5.5

D. Do not place the WIT Inverter in an enclosed and narrow space for operation.

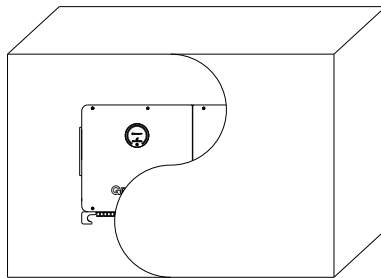

Fig 5.6

### 5.3 Moving the WIT Inverter



**CAUTION**

- The inverter is heavy, please move it with care and keep balance to avoid personnel injury.
- Do not place the inverter with its wiring and signal terminals at the bottom contacting with floor or any other object because the terminals are not designed to support the weight of inverter.

- 1> As shown in Fig 5.7, two persons are required to lift the inverter out of the package and transport it to the installation position.
- 2> When you are moving the inverter, please keep the balance.

**Notice:** There will be front and bottom mark on the package.

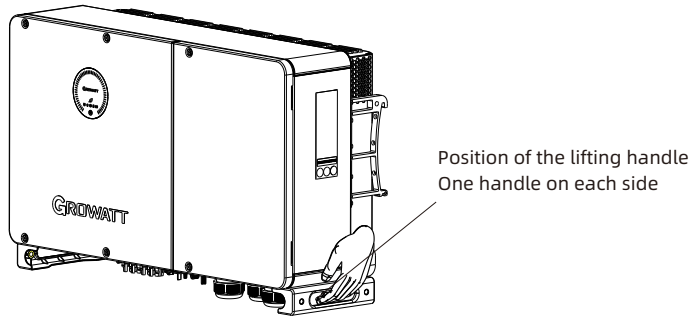

Fig 5.7

### 5.4 Wall Mount Bracket Installation

Before installing the inverter, you need install the wall mount bracket so that the inverter can be securely mounted on the wall.

Wall mount bracket (unit: mm):

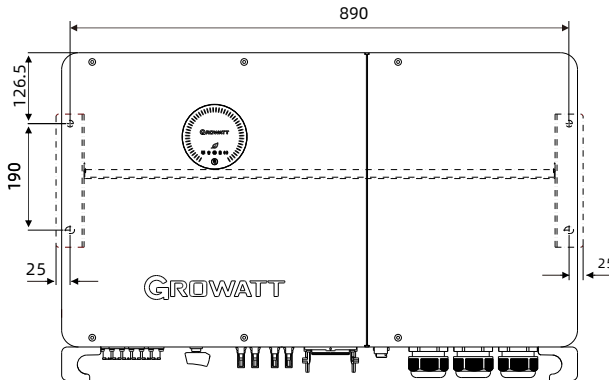

Fig 5.8

**STEP 1:** Use the wall mount plate as a template, drill holes into the wall and insert the expansion bolts as Fig 5.9 show.

**STEP 2:** Tighten the bolts to attach the wall mount bracket onto the wall securely as illustrated below.

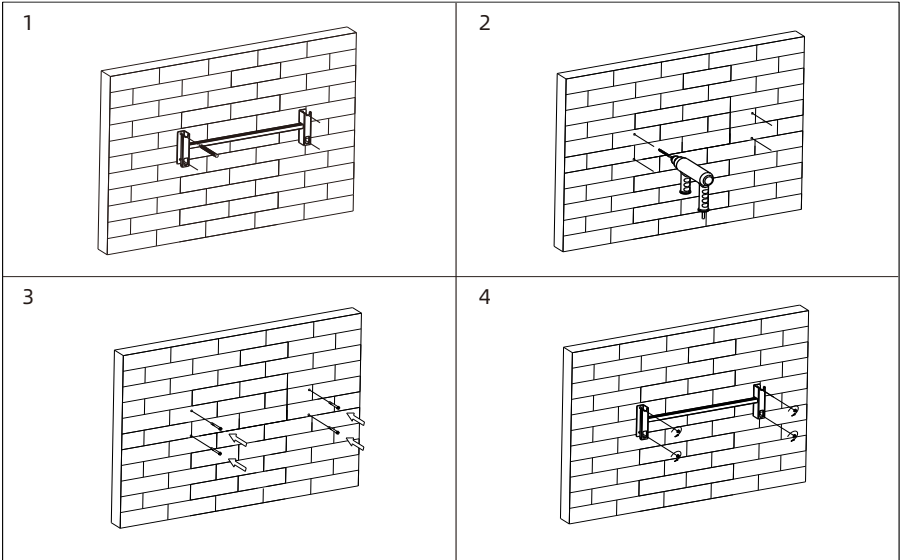

Fig 5.9

**Note:**

- 1> The wall where the expansion bolts are installed should be a solid concrete or brick wall with a thickness of at least 100 mm.
- 2> Ensure that the bracket has been firmly installed before mounting the inverter onto it.

### 5.5 Installing the Inverter

After verifying that the wall mount bracket has been firmly installed on the wall, mount the inverter onto the bracket.

- 1> Run the rope, which is strong enough to bear the weight of the inverter, through the two hoist rings, as shown below;
- 2> Hang the inverter onto the wall mount bracket and install the bolts. Please keep balance when moving the inverter.
- 3> Check if the inverter has been properly mounted and tighten all screws.

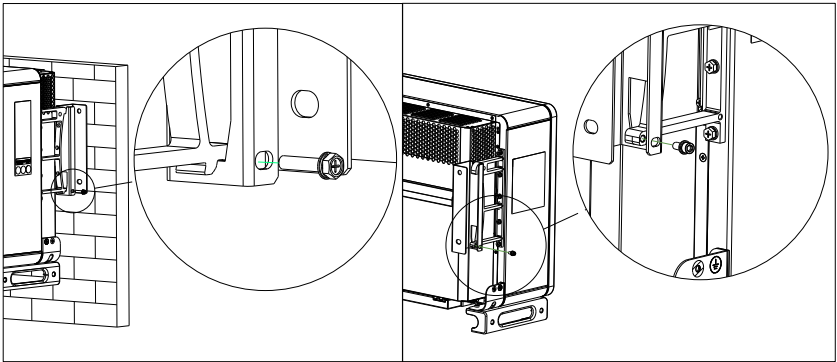
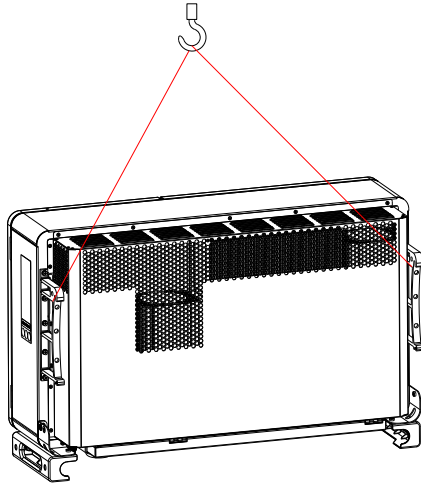

Fig 5.10 Wall-mounted installation



Ensure that the wall meets the load-bearing requirements of the equipment. For details about the weight, see Table 3.2.

# 6 Electrical Connection

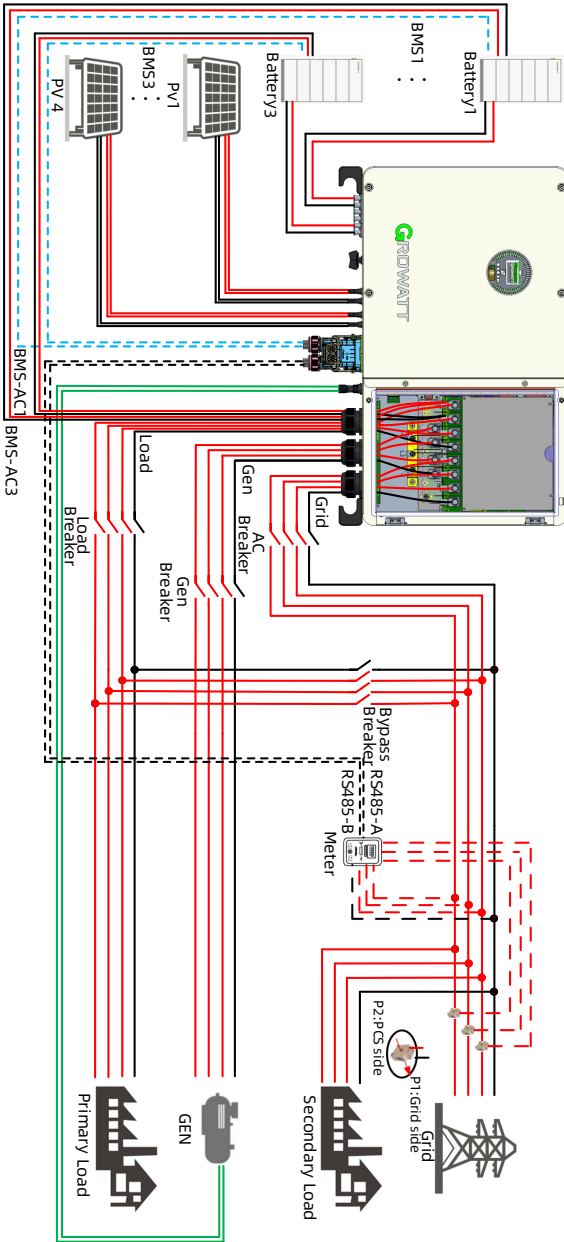

Fig 6.1 Wiring diagram of the system with a single WIT 50K-XHU inverter (Gen mode)

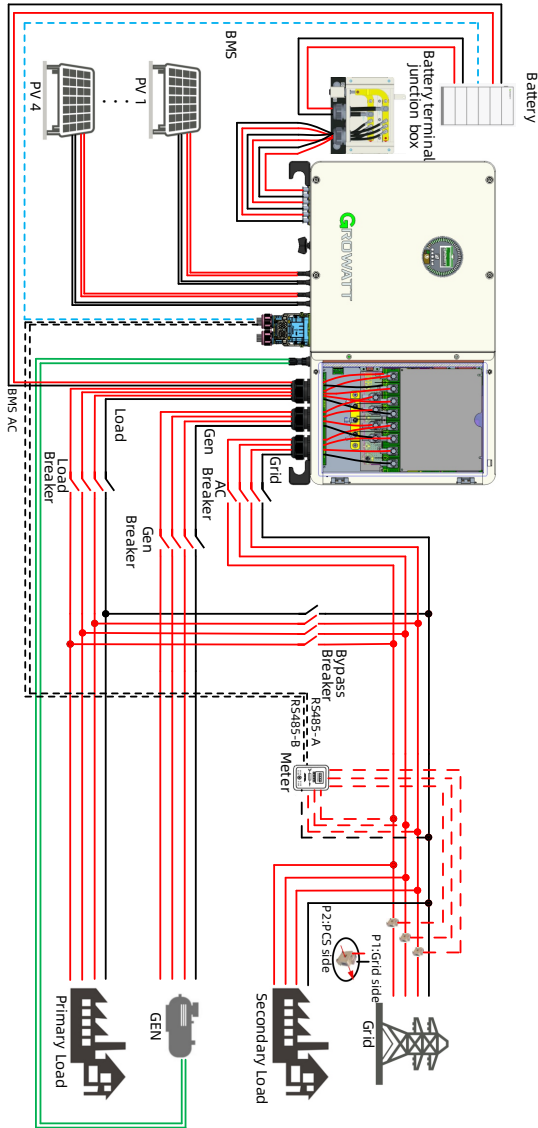

Fig 6.2 Wiring diagram of the system with a single WIT 50K-XHU inverter (with the WIT-XHU battery terminal junction box)

**NOTE:**

1. The WIT-XHU battery terminal junction box is optional;
2. When one cluster of battery is connected, run the power cables through the battery terminal junction box and the BMS communication cable should be connected to BMS1 on the COM1 port.

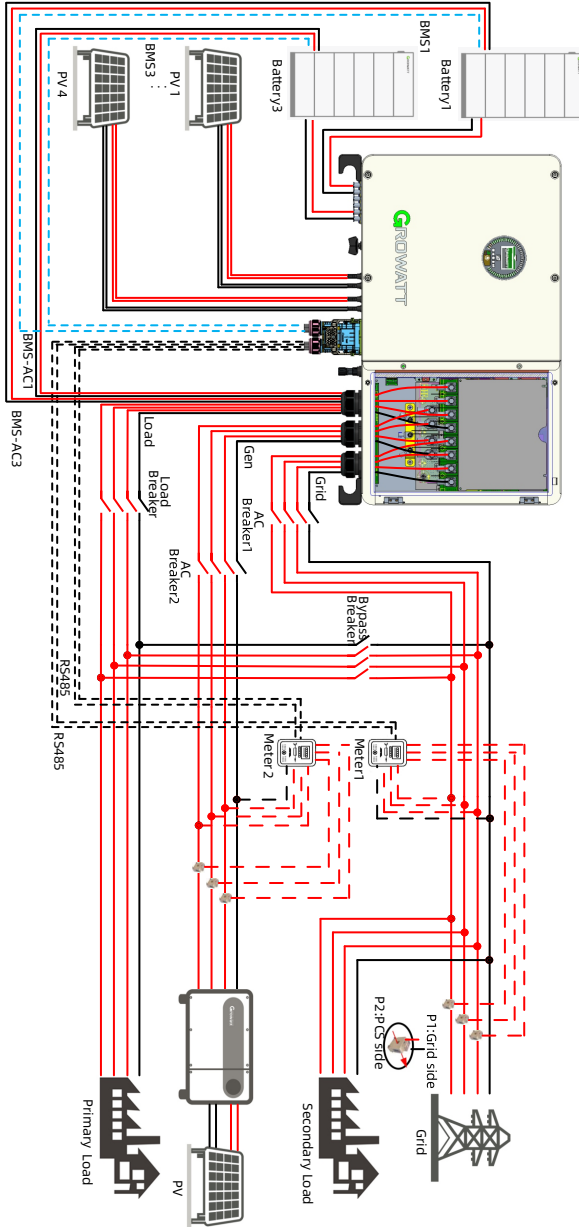

Fig 6.3 Wiring diagram of the system with a single WIT 50K-XHU inverter and two meters (AC couple mode)

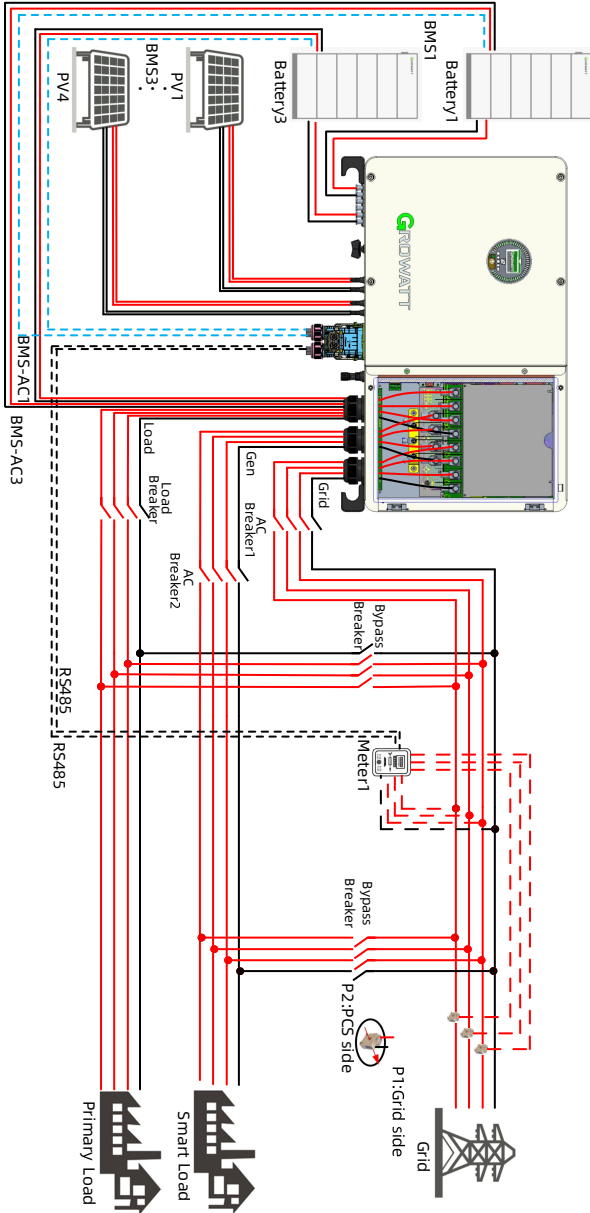

Fig 6.4 Wiring diagram of the system with single WIT 50K-XHU inverters in smart load mode

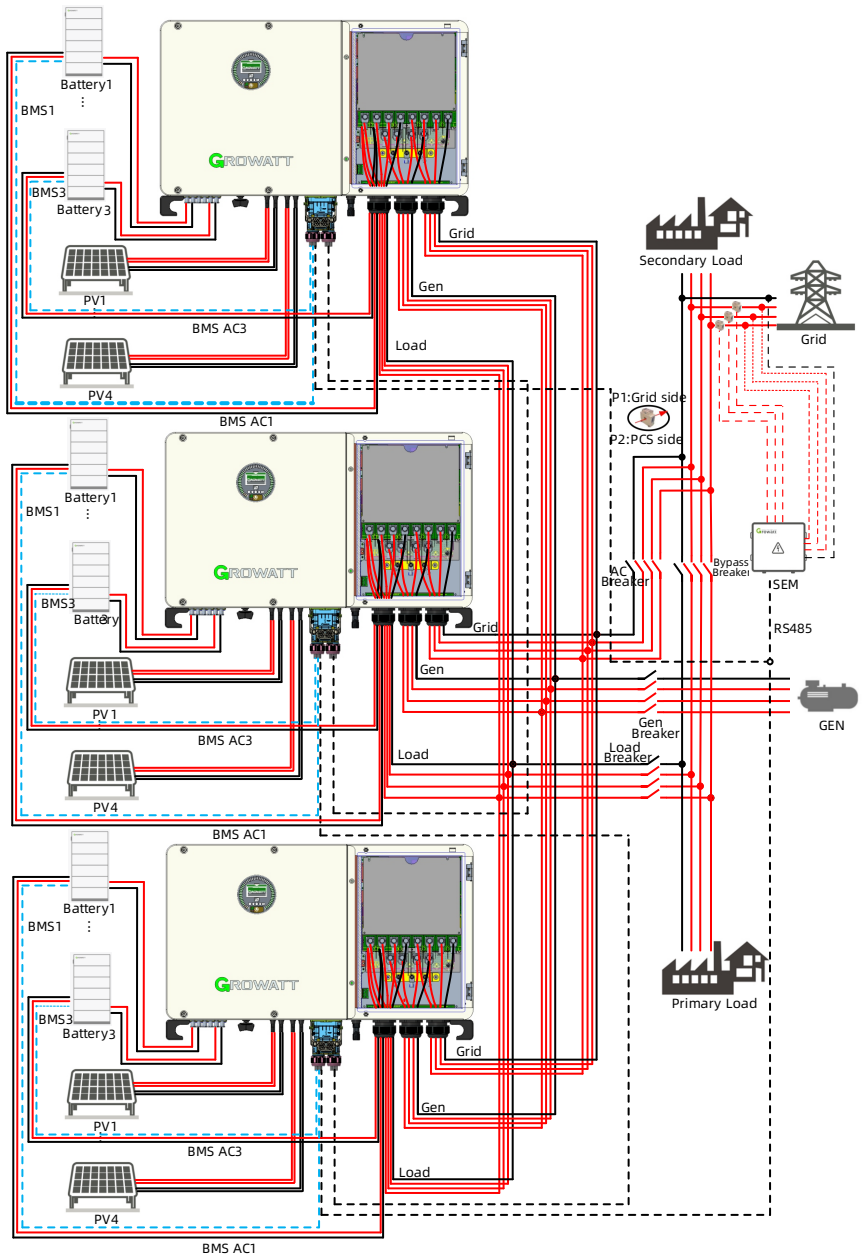

Fig 6.5 Wiring diagram of the system with three WIT 50K-XHU inverters connected in parallel



Wiring modes vary depending on the region as shown in Fig 6.7 below. Please select the appropriate wiring mode according to locally applicable safety standards.

Fig6.7(a): Neutral line of alternative supply must not be isolated or switched.

Fig.6.7(b): Neutral line of alternative supply can be isolated or switched.

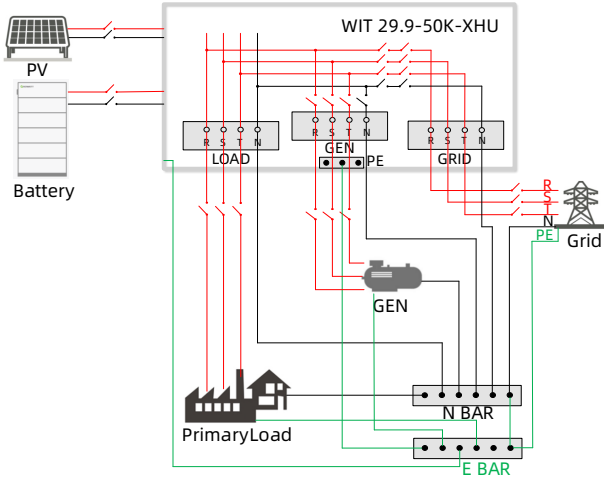

(a) Wiring mode for AU/NZ

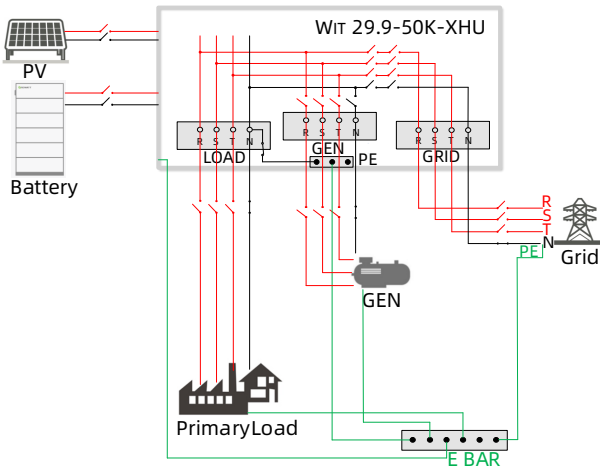

(b) Wiring mode for other regions

Fig 6.7 Wiring modes for different regions

## 6.1 Connecting The Ground Cables

1. It is essential to connect the ground cable to the WIT inverter before connecting other cables to prevent personal injury or device damage.
2. All non-current-carrying metal parts and the enclosures of the devices of the energy storage system, including the rack and the enclosures of the combiner box, the distribution panel, the inverter and the battery should be properly grounded.
3. For a single WIT inverter, connect a ground cable to the ground point on the chassis shell. For a system with multiple WIT inverters connected in parallel, ensure that the enclosures of the WIT Inverters, the metal racks of the PV modules and the batteries should be connected to the same area to achieve equipotential bonding.
4. The position of the ground points of the WIT 29.9-50K-XHU Hybrid Inverter is shown in Fig 6.8.

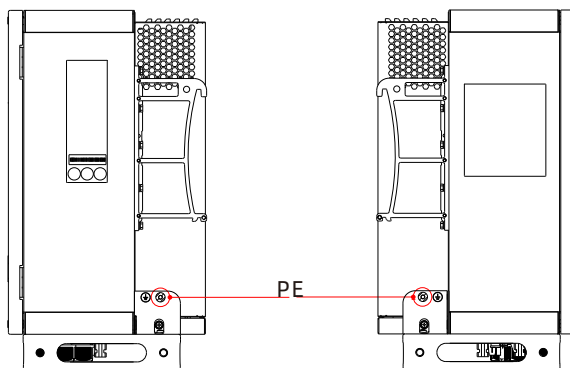



Fig 6.8 Ground points

### NOTE:

1. Keep the lightning protection grounding at the greatest possible distance from the protective grounding.
2. Protect the terminals of the ground cables against rain and do not expose them to open air.
3. Tighten the screws to a torque of 60 kgf·cm.

## 6.2 Connection on the AC Side

 <p><b>DANGER</b></p>	<ul style="list-style-type: none"> <li>• Before connecting cables, ensure that the DC switches on the WIT Inverter are OFF. Turn off the switches and breakers on the GRID side, GEN side and the battery side. Otherwise, the high voltages of the WIT Inverter may result in electric shocks.</li> <li>• Only qualified and trained electrical technicians are allowed to perform operations. Technicians must observe instructions in this manual and local regulations.</li> <li>• High voltages may cause electric shocks and serious injury. Please do not touch the inverter in operation.</li> <li>• Do not place inflammable and explosive materials around the WIT Inverter.</li> </ul>
 <p><b>WARNING</b></p>	<ul style="list-style-type: none"> <li>• Each WIT Inverter must be equipped with a separate AC circuit breaker. Multiple WIT Inverters cannot connect to the same AC circuit breaker (not applicable to off-grid mode).</li> <li>• Please do not connect loads between the WIT Inverter and the circuit breaker.</li> <li>• If the cable is thick, do not wiggle the cable after tightening the cable terminals. Otherwise, the loose connection may cause overheating that will damage the device. Ensure that the terminals are properly connected before starting the WIT Inverter.</li> <li>• Upon completion of the AC wiring, remember to seal the waterproof silicone mat with the fireproof mud in order to ensure good waterproof performance.</li> </ul>

Preparation:

- 1> Ensure the grid voltage and the grid frequency are within the acceptable range;
- 2> Disconnect the DC switches and the AC breakers on the grid side, generator side and the battery side.

### The circuit breaker on the AC side:

AC circuit breaker needs to be installed on the grid side, ensuring a safe disconnection between the WIT Inverter and the upstream input when an exception occurs.

1. Recommended AC breaker specifications for WIT 29.9-50K-XHU models

Device type	Rated voltage of the circuit breaker	Rated current of the circuit breaker
WIT 29.9K-XHU	400V	150A
WIT 30K-XHU	400V	150A
WIT 36K-XHU	400V	150A
WIT 40K-XHU	400V	200A
WIT 50K-XHU	400V	250A

2. Recommended load breaker specifications for WIT 29.9-50K-XHU models

Device type	Rated voltage of the circuit breaker	Rated current of the circuit breaker
WIT 29.9K-XHU	400V	80A
WIT 30K-XHU	400V	80A
WIT 36K-XHU	400V	80A
WIT 40K-XHU	400V	100A
WIT 50K-XHU	400V	125A

3. Recommended bypass breaker specifications for WIT 29.9-50K-XHU models

Device type	Rated voltage of the circuit breaker	Rated current of the circuit breaker
WIT 29.9K-XHU	400V	80A
WIT 30K-XHU	400V	80A
WIT 36K-XHU	400V	80A
WIT 40K-XHU	400V	100A
WIT 50K-XHU	400V	125A

4. Recommended Gen breaker specifications for WIT 29.9-50K-XHU models

Device type	Rated voltage of the circuit breaker	Rated current of the circuit breaker
WIT 29.9K-XHU	400V	150A
WIT 30K-XHU	400V	150A
WIT 36K-XHU	400V	150A
WIT 40K-XHU	400V	200A
WIT 50K-XHU	400V	250A

**NOTE:**

For the PCS to operate in Smart Load mode, select the appropriate AC breaker based on the smart load power.

**Recommended power cable specifications:**

1. Recommended AC power cable specifications for WIT 29.9-50K-XHU models.

Device type	GRID Recommended cable specification	LOAD Recommended cable specification	GEN Recommended cable specification
WIT 29.9K-XHU	35mm <sup>2</sup>	25mm <sup>2</sup>	35mm <sup>2</sup>
WIT 30K-XHU	35mm <sup>2</sup>	25mm <sup>2</sup>	35mm <sup>2</sup>
WIT 36K-XHU	35mm <sup>2</sup>	25mm <sup>2</sup>	35mm <sup>2</sup>
WIT 40K-XHU	50mm <sup>2</sup>	35mm <sup>2</sup>	50mm <sup>2</sup>
WIT 50K-XHU	50mm <sup>2</sup>	35mm <sup>2</sup>	50mm <sup>2</sup>

**AC side connection steps:**

1. Open the right cover plate. The position of the cover is shown in Fig 6.9;

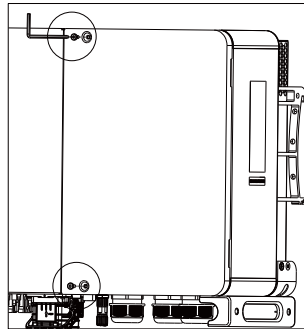

Fig 6.9

2. Connect a ground cable to the copper grounding bar. Fig 6.10 shows the position of the grounding bar inside the right cover plate;

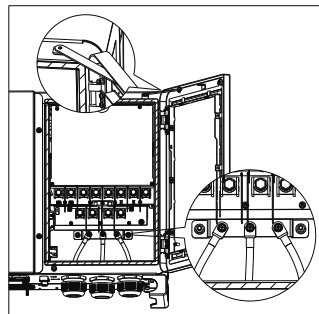

Fig 6.10

3. Connect the main power cables according to the label. Fig 6.11 shows the position of the label and the AC terminals.

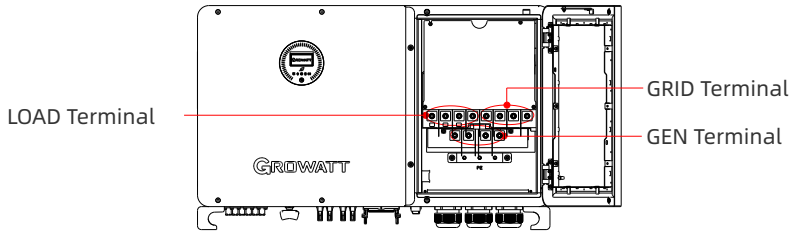

Fig 6.11 AC terminal wiring position and diagram

**NOTE:**

1. Determine the stripped length based on the wiring terminal specifications (recommended length: 22-26 mm). Crimp the cable and terminal using a crimping tool as shown below. Loosen the PG type cable gland and route the cables through it. Then connect the cables to the corresponding terminals. Secure the cables by tightening the screws.

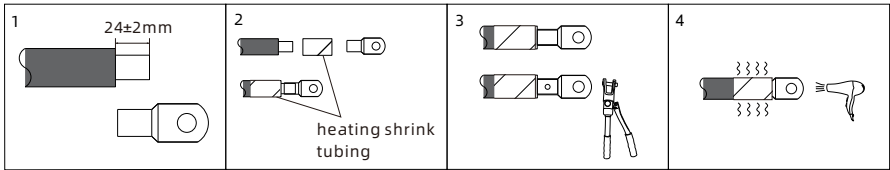

Fig 6.12 Crimping a cable

2. Cold-pressed terminals are delivered with the package. Select terminals based on the cable specifications;
3. After connecting the cables, apply fireproof mud to the waterproof silicone mat at the inlet side. Lock the cover of the AC junction box after the fireproof mud is applied. See Fig 6.13 below.

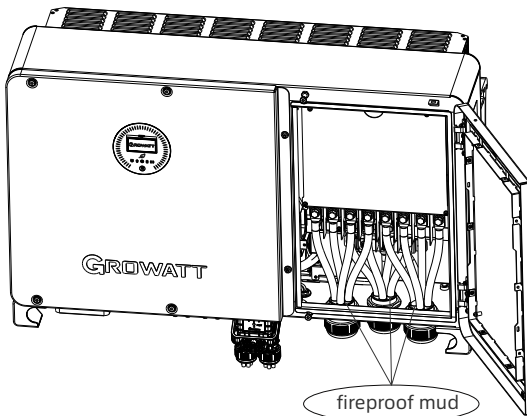

Fig 6.13 Applying fireproof mud



**WARNING**

- Any device damage caused by failure to seal the output terminal gaps as instructed is beyond the scope of warranty and Growatt shall not be liable for the damage.

### 6.3 Connection on the PV Side



**DANGER**

- Before connecting cables, ensure that the DC switches of the WIT Inverter are OFF, and turn off the breakers on the AC side and the battery side. Otherwise, the high voltages of the WIT Inverter may cause electric shocks.
- Only qualified and trained electrical technicians are allowed to perform operations. Technicians must observe instructions in this manual and local regulations.
- Check the positive and negative terminals before connecting the PV module to the WIT Inverter.
- High voltages may cause electric shocks and serious injury. Please do not touch the inverter in operation.
- Please do not place inflammable and explosive materials around the WIT Inverter.



**WARNING**

- The maximum open-circuit voltage of each string should not exceed 1100Vdc.
- Ensure that the following conditions are met; Otherwise, fire hazard or inverter damage may occur. Growatt is not liable for the consequence and it is beyond the warranty scope.

#### **NOTE:**

1. When exposed to sunlight, PV modules will generate voltage. High voltages presented in the PV strings connected in series could be fatal. Therefore, shield the PV modules from sunlight before connecting the DC input power cable and ensure that the DC switches on the WIT Inverter are OFF.
2. The PV modules connected in series should be of the same model.
3. The maximum short-circuit current of each PV string must be lower than or equal to 50A.
4. The total panel power should not exceed twice the WIT Inverter input power.
5. For optimal system configuration, it is recommended to connect two DC inputs with an equal number of PV modules.

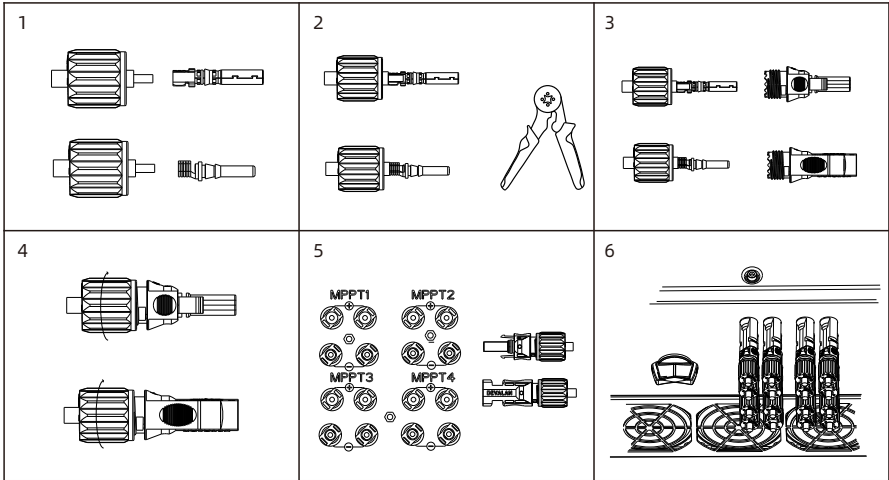

Fig 6.14 PV terminals

**Procedure for connecting cables on the PV side:**

1. Strip 6-8 mm of the insulation layer of the PV cables.
2. Insert the exposed core wires into the crimping area of the wiring terminal and crimp them using a crimping plier;
3. Route the cable through the cable sealing sleeve and insert the insulation sleeve until it snaps. Slightly pull the cable back to ensure that it is securely connected. Then tighten the locking nut;
4. Insert the positive and negative connectors of the PV modules to the corresponding terminals on the inverter. For the maximum input current of different models, please see Table 6.1. For the cable specifications, please see Table 6.2.

Table 6.1 Maximum current of a single MPPT route

Device type	Max. current of a single MPPT route
WIT 29.9K-XHU	40A
WIT 30K-XHU	40A
WIT 36K-XHU	40A
WIT 40K-XHU	40A
WIT 50K-XHU	40A



Table 6.2 Cable specifications on the PV side

Device type	Recommendation cable specifications
WIT 29.9K-XHU	4-6mm <sup>2</sup>
WIT 30K-XHU	4-6mm <sup>2</sup>
WIT 36K-XHU	4-6mm <sup>2</sup>
WIT 40K-XHU	4-6mm <sup>2</sup>
WIT 50K-XHU	4-6mm <sup>2</sup>

**NOTE:**

1. For a single WIT Inverter, connect the ground cable of the inverter. For a system with multiple WIT Inverters connected in parallel, connect the ground cables of all inverters and the metal racks of the PV modules to the same area to ensure equipotential bonding. Before connecting the PV cables, ensure that the ground cables on the PV side are properly connected.
2. Use male and female connectors in pair. Ensure the correct polarity before connecting the PV string to the inverter.
3. The total current of all strings cannot exceed the WIT Inverter's maximum input current;
4. Do not touch the solar panels in operation;
5. The wires should be tinned and are not frayed or cracked.

### 6.4 Connection on the Battery Side

 <b>DANGER</b>	<ul style="list-style-type: none"> <li>• Before connecting cables, ensure that the DC switches of the WIT Inverter are OFF, and turn off the breakers on the AC side and the battery side. Otherwise, the high voltages of the WIT Inverter may cause electric shocks.</li> <li>• Only qualified and trained electrical technicians are allowed to perform operations. Technicians must observe instructions in this manual and local regulations.</li> <li>• High voltages may cause electric shocks and serious injury. Please do not touch the inverter in operation.</li> <li>• Please do not place inflammable and explosive materials around the WIT Inverter.</li> </ul>
 <b>WARNING</b>	<ul style="list-style-type: none"> <li>• Ensure that all cables are securely connected before powering on the WIT Inverter. Loose connection may cause overheating that will damage the device.</li> </ul>

**NOTE:**

The recommended battery voltage is 512V.

Table 6.3 Cable specifications on the Battery side

Device type	Recommendation cable specifications
WIT 29.9K-XHU	16mm <sup>2</sup>
WIT 30K-XHU	16mm <sup>2</sup>
WIT 36K-XHU	16mm <sup>2</sup>
WIT 40K-XHU	16mm <sup>2</sup>
WIT 50K-XHU	16mm <sup>2</sup>

### 6.4.1 Connecting the Main Power Cable of the Battery

#### Preparation:

1. Check that the battery terminals of the WIT Inverter are intact;
2. Disconnect the DC switches on the WIT inverter, the AC breaker and the DC switch on the battery;
3. Take out the battery terminals from the accessory kit delivered with the package. See Packing List in Section 4;

#### Procedure for connecting the main battery power:

1. Connect the ground cable to the battery power ground bar, as shown in Fig 6.10;
2. Strip 11.5-12.5 mm of the insulation layer of the DC cables;
3. Crimp the battery cables and the battery terminals using crimping pliers, and then tighten the insulation sleeve;
4. Connect the battery cables to the battery terminals on the inverter, as shown in Fig 6.15;

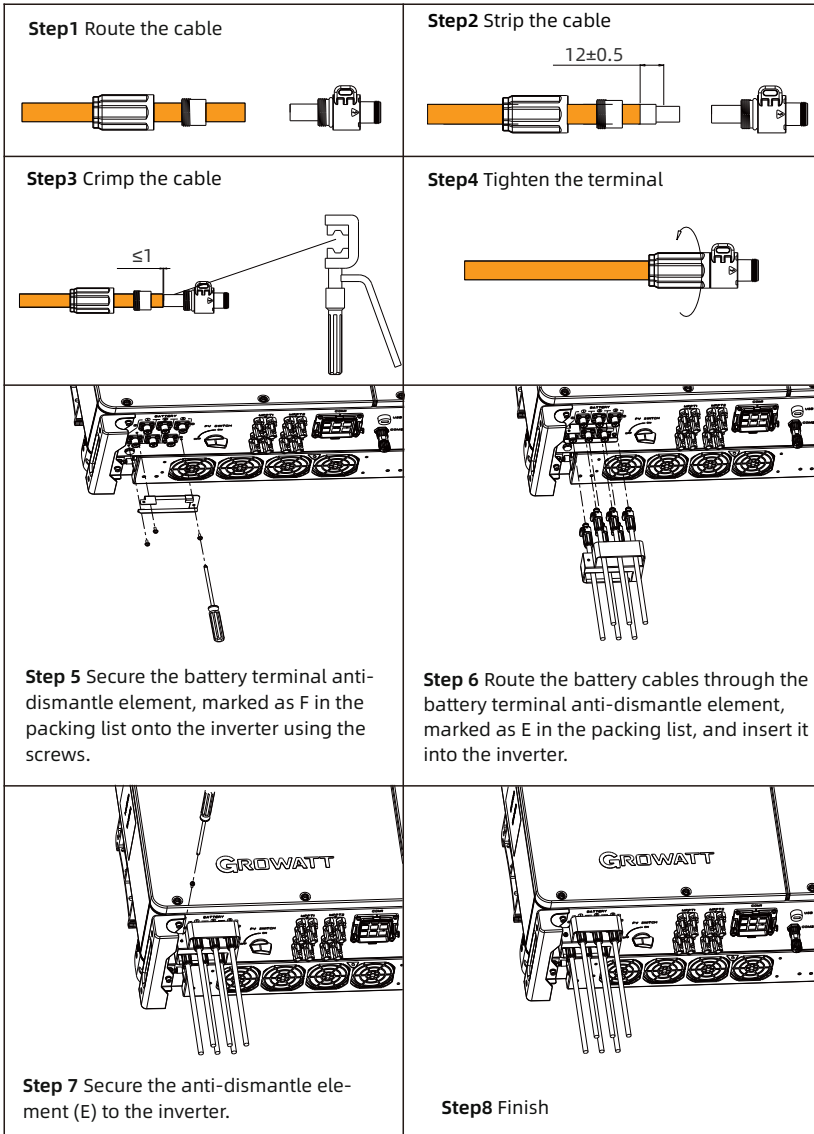

Fig 6.15 Position of the battery terminals

**NOTE:**

- 1> Connect the ground cable before connecting the battery cable; the ground point is shown in Fig 6.10.
- 2> The length of the battery cable is recommended to be no more than 10m.

## 6.4.2 Connecting the Battery BMS-AC terminal

**NOTE:** Perform operations according to on-site requirements.

### Procedure for connecting the battery BMS-AC terminal:

1. Open the right cover plate of the inverter, the position of which is shown in Fig 6.16;
2. Find the corresponding terminals from the accessory kit. Refer to Table 6.4 to connect the terminals;

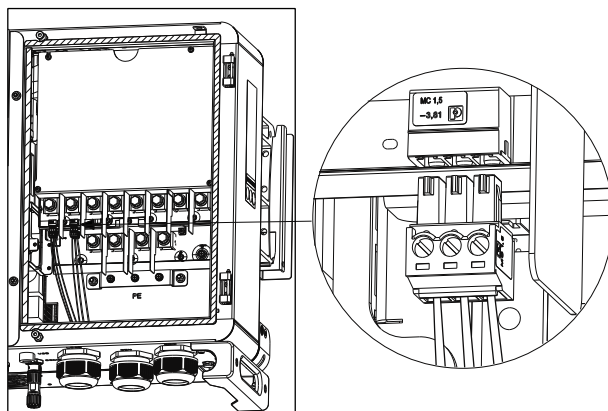

Fig 6.16 BMS-AC terminal

Table 6.4 Definitions of BMS-AC terminal

BMS-AC terminal port definition		
Number	Definition of signal	Note
CN4/CN5/CN6	LOAD R/LOAD S/LOAD T	Supply power to the BMS
CN7	LOAD N	

**NOTE:**

1. Reinstall the battery protective plate and the right cover plate after the cable connection is completed.
2. Select phase or line voltage according to actual needs.

# 6.5 Connecting Communications Cables

## 6.5.1 COM1 Connection

The COM1 terminal of the WIT 29.9-50K-XHU Inverter includes 9 RJ45 ports. It is used for parallel connection via PARA-IN and PARA-OUT communication terminals, battery communication via BMS1, BMS2 and BMS3 terminals, and external equipment communication via RS485 and DRMs function. Connect the communication cables to the corresponding terminals as required. For details, see Table 6.5;

### Procedure for connecting the COM1 terminal:

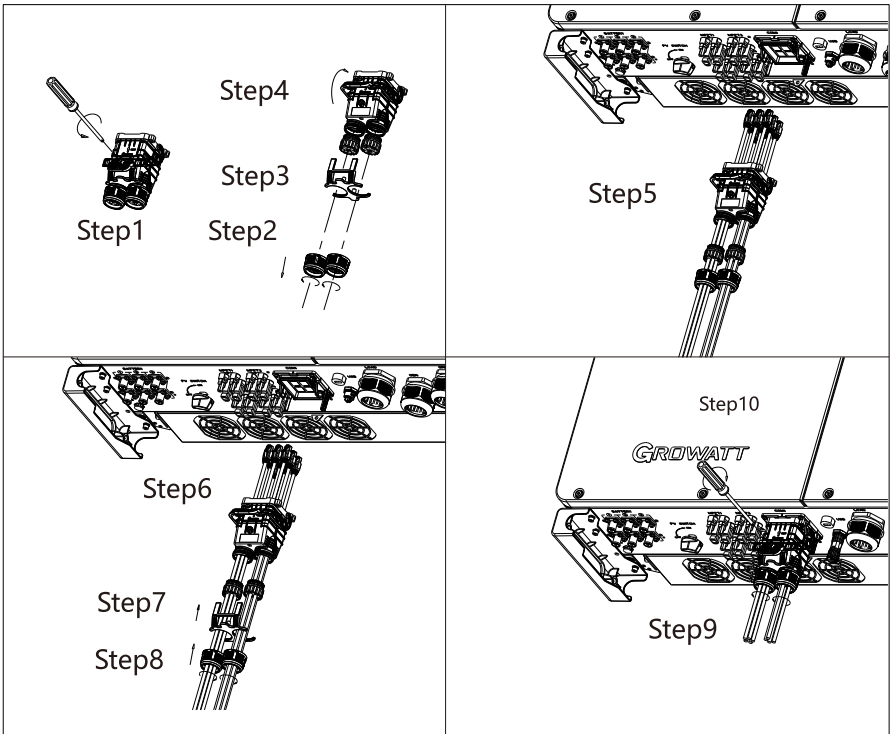

Fig 6.17

- 1> Remove the fixing screws and disassemble the COM1 waterproof cover as Step 1-4 show;
- 2> Crimp the communication cable as follows:

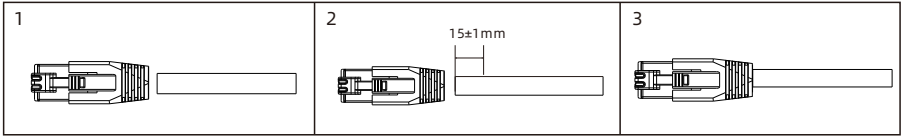

Fig 6.18

Loosen the cable gland and remove the watertight caps inside the cable gland based on the number of the cables and keep the unused holes with watertight cap. Lead the cable into the holes in the cable gland (the 5-hole fastening rings inside the cable gland are with openings on the side. Please separate the gap with hand and squeeze the cables into the holes from the side openings. Hole diameter: 5.5~7.0 mm). Route the cables through the COM1 terminal waterproof cover as Step 5 shows. Connect the cable to the corresponding terminal.

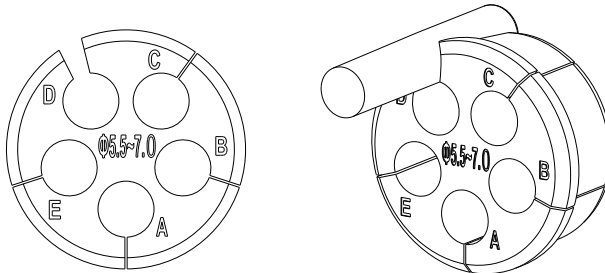

Fig 6.19

3> Tighten the COM1 terminal cover as Step 6-8 shows.

4> Secure the screws as Step 9 shows.

### Detailed information of COM1

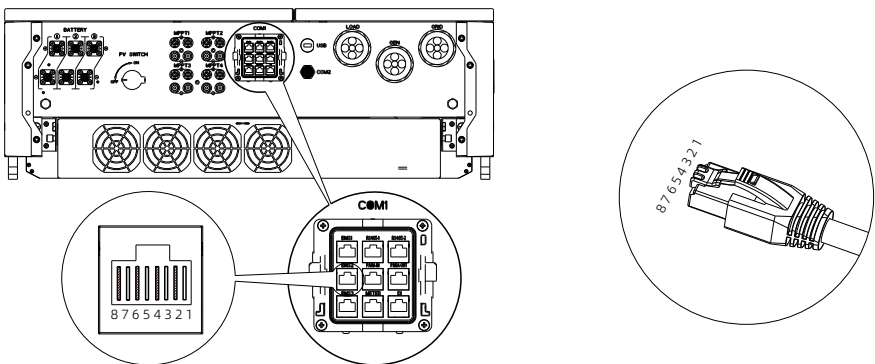

Fig 6.20 COM1 communication terminal

Table 6.5 COM1 communication terminal description

<b>Definition of battery communication terminal</b>			
<b>Silk screen</b>	<b>Pin</b>	<b>Definition of signal</b>	<b>Function and Note</b>
BMS1	1	BAT RS485_B	Communication of battery1 (mandatory)
	2	BAT RS485_A	
	3	BAT1 DI_1	
	4	BAT1 CAN_H	
	5	BAT1 CAN_L	
	6	BAT1 DI_2	
	7	BAT1 WAKE-(GND.S)	
	8	BAT1 WAKE+	
BMS2	1	BAT RS485_B	Communication of battery2 (mandatory)
	2	BAT RS485_A	
	3	BAT2 DI_1	
	4	BAT2 CAN_H	
	5	BAT2 CAN_L	
	6	BAT2 DI_2	
	7	BAT2 WAKE-(GND.S)	
	8	BAT2 WAKE+	
BMS3	1	BAT RS485_B	Communication of battery3 (mandatory)
	2	BAT RS485_A	
	3	BAT3 DI_1	
	4	BAT3 CAN_H	
	5	BAT3 CAN_L	
	6	BAT3 DI_2	
	7	BAT3 WAKE-(GND.S)	
	8	BAT3 WAKE+	

Definition of battery communication terminal			
Silk screen	Pin	Definition of signal	Function and Note
RS485-1	1	RS485_1B	RS485-1: Meter2/ShineBus/ ShineMaster (1/4/5) RS485-3: EMS/VPP(7/8)
	2	GND.S	
	3	/	
	4	RS485_1B	
	5	RS485_1A	
	6	/	
	7	RS485_3B	
	8	RS485_3A	
RS485-2	1	RS485_1B	RS485-1: Meter2/ShineBus/ ShineMaster (1/4/5) RS485-3: EMS/VPP(7/8)
	2	GND.S	
	3	/	
	4	RS485_1B	
	5	RS485_1A	
	6	/	
	7	RS485_3B	
	8	RS485_3A	
METER	1	RS485_2B	RS485_2: METER1 output (export limitation meter wiring port for a single inverter)
	2	GND.S	
	3	/	
	4	/	
	5	RS485_2A	
	6	/	
	7	/	
	8	/	

Definition of battery communication terminal			
Silk screen	Pin	Definition of signal	Function and Note
DI	1	DRM1/5	DRMS/RCR/DI function
	2	DRM2/6	
	3	DRM3/7	
	4	DRM4/8	
	5	REF	
	6	COM	
	7	/	
	8	/	
PARA-IN	1	/	Parallel input
	2	GND.S	
	3	Sc_A/H	
	4	PL_CANH	
	5	PL_CANL	
	6	Sc_B/L	
	7	GND.S	
	8	master_CAN	
PARA-OUT	1	/	Parallel output
	2	GND.S	
	3	Sc_A/H	
	4	PL_CANH	
	5	PL_CANL	
	6	Sc_B/L	
	7	Slave_CAN	
	8	GND.S	

### 6.5.2 COM2 Connection

The COM2 terminal is used for Generator start-up and emergency stop.

1. Strip 23-27 mm of the cable jacket and 8-12mm of the wire insulation.
2. Crimp the COM2 cable and the terminal using a crimping plier, and then tighten the insulation sleeve;
3. Connect the COM2 cable to the COM2 terminal on the inverter, as shown in Fig 6.21;

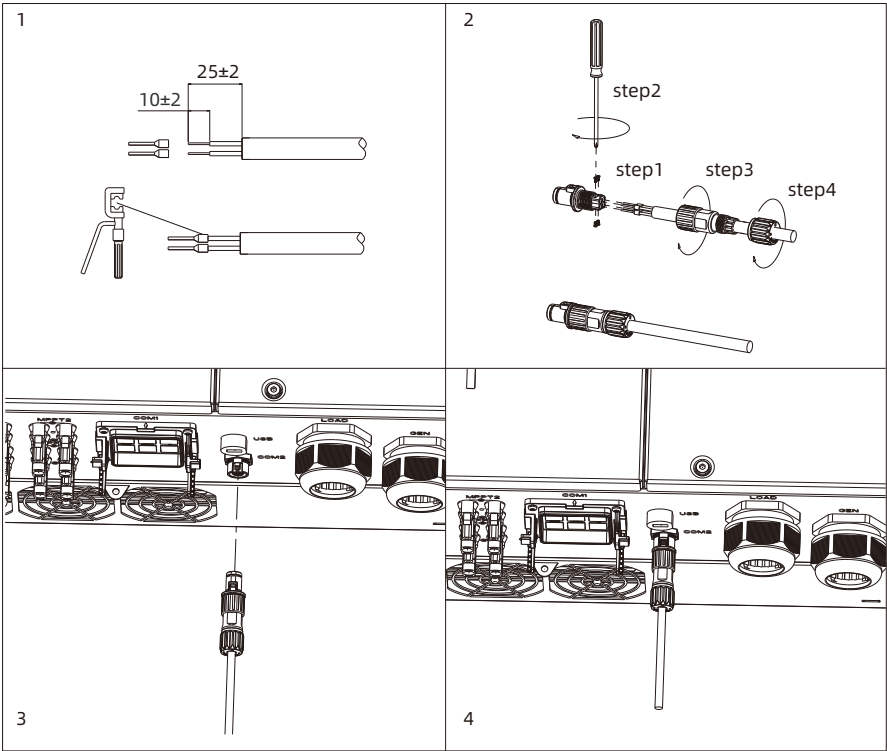

Fig 6.21 Connecting to the COM2 terminal

**NOTE:**

The external communication terminal of the WIT 29.9-50K-XHU Inverter is a 4-pin connector. The matching terminal is in the accessory kit. The connection procedure is as follows:

1. Connect the communication cable to the corresponding terminal as required.

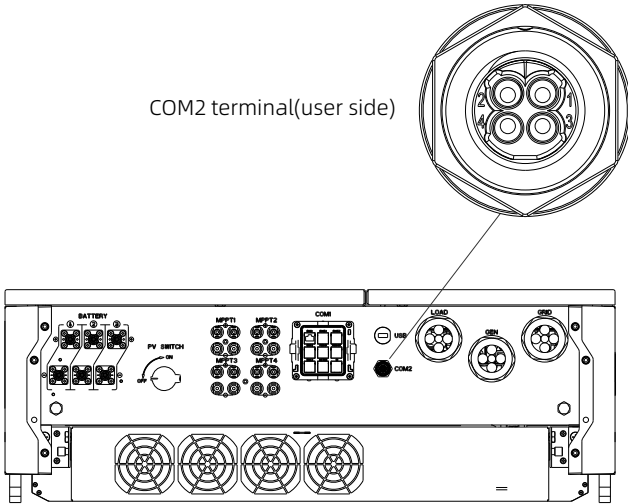

Fig 6.22 COM2 communication terminal

2. The COM2 communication terminal contains two dry contacts (voltage free). PIN 1 and 2 are for emergency stop signal; PIN 3 and 4 are for DG start-up signal.

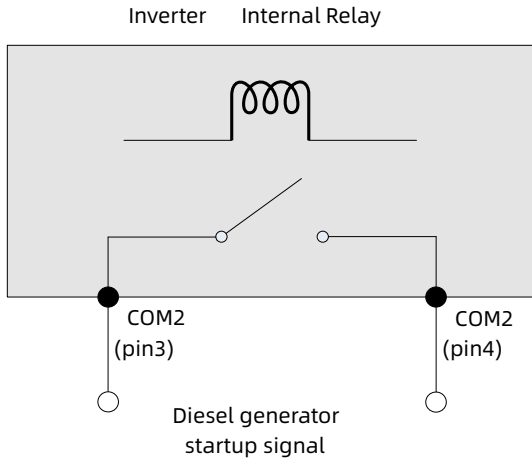

Fig 6.23

**Note:** Maximum dry contact input: 24VDC 1A.

### 6.5.3 USB connection

The WIT-XHU series inverter is equipped with a USB interface as standard, which can be connected to a USB to WiLAN-X2 monitoring module for remote monitoring. In addition, you can also quickly upgrade the inverter software through the U disk. Steps to install the monitoring module:

- 1> Loosen the waterproof cover of the USB interface and remove it.
- 2> As shown in Fig 6.24, insert the WiLAN-X2 module into the USB interface, and the LED indicator of the WiLAN-X2 module will be on.
- 3> As shown in Fig 6.24, make sure that the ▲ is facing frontwards as the inverter has been wall-mounted, insert the monitoring module into the USB interface, and tighten the lock.

**Note:**

If a USB to WiLAN-X2 module is installed, please take the module and the data cable away, and tighten the waterproof cover when the operator leaves to prevent water from entering the interface.

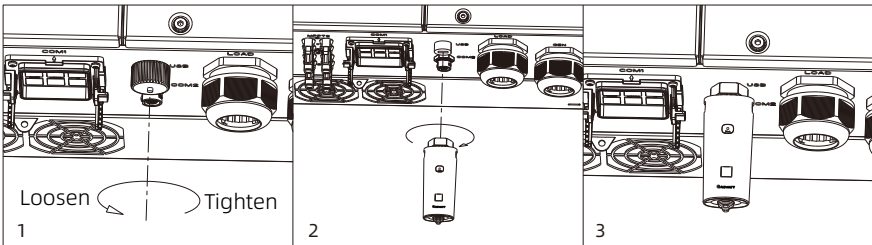

Fig.6.24 USB Connection

## 6.6 Post-installation Checks

The following table lists the post-installation items to be checked:

Position	Item	Check item
	Ground cable connected to the chassis	Check the cable specifications; ensure that the cable has been securely fastened
AC side	Ground cable on the AC side	Check the cable specifications; ensure that the cable has been securely fastened
	Grid side	Check the cable specifications; ensure that the cable has been securely fastened
	Load side	Check the cable specifications; ensure that the cable has been securely fastened
	GEN side	Check the cable specifications; ensure that the cable has been securely fastened
	Waterproof silicone gel mat	No gap exists; the fireproof mud has been evenly applied
	Right cover plate	Re-install the cover and secure it with screws after checking all items on the AC side
PV side	Ground cable on the PV side	Check the cable specifications; ensure that the cable has been securely fastened
	PV+/PV-	Check the cable specifications; ensure that the cable has been securely fastened; confirm that the number of PV modules matches the rated power
Battery side	Ground cable on the battery side	Check the cable specifications; ensure that the cable has been securely fastened
	BAT+/BAT-	Ensure that the positive and negative terminals are connected correctly and securely; the sealing rubber ring is properly seated into the gland
	BMS-AC	Ensure that the connection is correct and secured; the sealing rubber ring is properly seated into the gland
	Cable bundling	The cables are bundled in the specified position

Position	Item	Check item
Communication terminals	COM1	Ensure that the connection is correct and secured; the sealing rubber ring is properly seated into the gland
	COM2	Ensure that the connection is correct and secured; the sealing rubber ring is properly seated into the gland
	USB	Ensure that the connection is correct and secured; the sealing rubber ring is properly seated into the gland

# 7 Commissioning

## 7.1 Commissioning the WIT Inverter



- The WIT Inverter might show wrong time and date if it has been stored for over a month. You need to set the correct time and date before connecting the WIT Inverter to the grid.

### 7.1.1 Set the Communication Address

After the WIT Inverter is powered on, you can set the communication address of the WIT Inverter via RS485 communication or the USB to WiLAN module. When multiple inverters are connected in parallel with RS485 hand-in-hand communication, each inverter should be set to different communication addresses. For a single inverter, the default communication address is set to 1.

#### **NOTE:**

The communication address of the WIT Inverter ranges from 1 to 254.

By connecting the WIT Inverter to the host computer through RS485 communication, you can change its communication address via ShineBus. This operation should be performed by professional personnel.

### 7.1.2 Set the Time and Date

#### 7.1.2.1 Set the time and date on the APP

Follow the instructions in Section 6.5.4 to connect the datalogger. When the inverter is powered in, you can set inverter time and date referring to Section 8.1.1. Tap Control > Set Inverter Time, then enter the password "growatt+date". For instance, if the date is Feb. 28, 2024, the password would be "growatt20240228". After that, tap "Yes".

1. Set the correct date, then click "OK". Proceed to set the time, and click "OK".

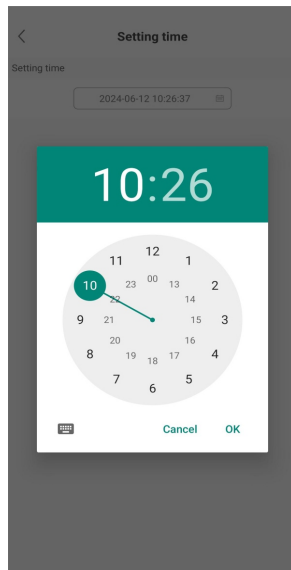
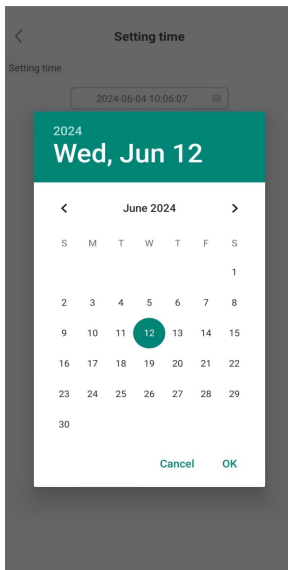
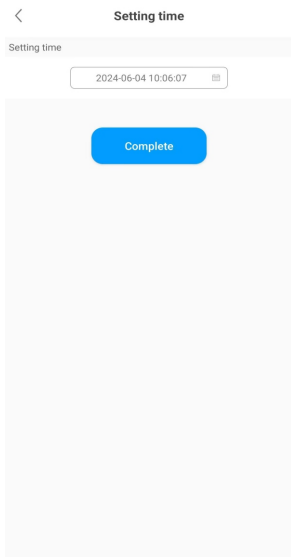

### 7.1.2.2 Set the Date & Time Automatically

Connect the WIT Inverter to the server following the procedure specified in Section 8.1.2 when the inverter is powered on, then the WIT Inverter will update its date and time automatically.

## 7.2 Mode of operation

### 7.2.1 Waiting Mode

When the PV voltage is greater than 180V, the WIT Inverter will be powered on and enters the waiting mode.

In waiting mode, the WIT Inverter performs self-check. If the system is normal and the voltage is greater than or equals to 195V, the WIT Inverter will be powered on.

## 7.2.2 Operating Mode

### 7.2.2.1 Operating Mode of WIT 29.9-50K-XHU

#### **Load First:**

In Load First mode, the WIT inverter prioritizes supplying the solar power and battery energy to the loads. If Export Limitation is disabled, the surplus solar power can be fed to the grid, but the battery energy will not be exported to the grid; if Export Limitation is enabled, neither solar power nor battery energy would be sent to the grid.

Priority of power supplied to the loads:

1. Solar panels;
2. Batteries;
3. Grid.

**NOTE:** In Load First mode, a meter is required.

#### **Battery First:**

In Battery First mode, the solar power is prioritized towards charging the battery until the battery SOC (state of charge) reaches the preset upper threshold. Then it will supply power to the loads. The further excess solar power, if any, can be fed to the grid (Export Limitation disabled). In case that the solar power is insufficient, the WIT inverter will draw power from the grid to charge the battery or supply the loads.

Priority of power directed to charge the battery:

1. Solar panels;
2. Grid.

#### **Grid First:**

In Grid First mode, the WIT inverter prioritizes supplying the solar power to the loads, exports the excess solar power to the grid, and sends the further surplus power to charge the power. If the solar power is insufficient to support the loads, the battery will discharge to supply power to the loads and the surplus battery power will be sent to the grid for revenue.

Priority of power supplied to the loads:

1. Solar panels;
2. Batteries;
3. Grid.

#### **Zero export to meter:**

With Export Limitation enabled, no solar power or battery energy will be fed to the grid in this mode. The inverter output is only supplied to the loads connected before the external meter connection point. A meter is required. For the meter wiring mode, please refer to Fig 6.6 in Chapter 6. The external meter will detect power flowing to the grid and regulate the generated power so that only so much energy is generated as is currently consumed by the primary loads, secondary loads and charging the battery.

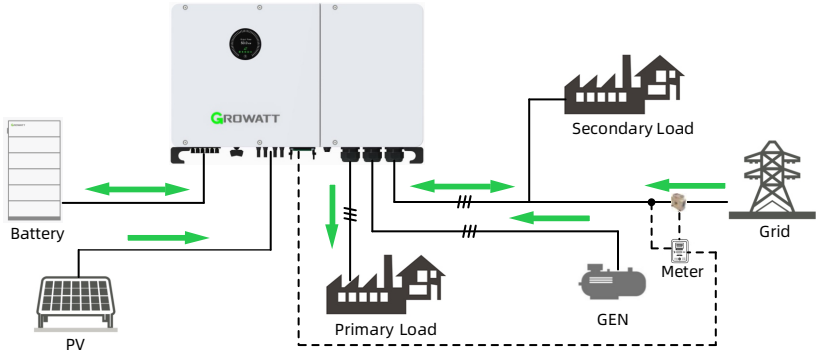

**Zero export to GRID:**

In this mode, there is no output at the inverter's GRID port. The solar and battery power can only be supplied to Primary Loads via the LOAD port. The meter is not required.

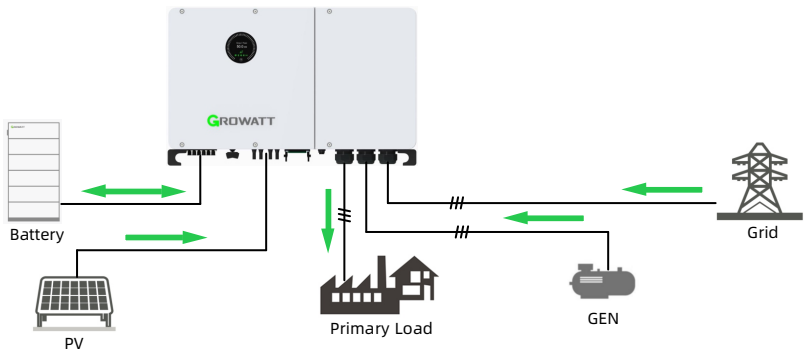

**Smart Load:**

Smart loads are connected to the GEN port and the Smart Load mode is set: during on-grid operation, it will supply grid power to smart loads; during off-grid operations, the power supply to smart loads is cut off. The wiring method is shown in Chapter 6 Fig 6.4.

**AC couple:**

The grid-tied inverter is connected to the GEN port and the AC Couple mode is set: during on-grid operation, the grid-tied inverter will be connected to the grid and generate electricity via the GEN port; during off-grid operation, the grid-tied inverter remains connected to the WIT inverter and generating power. The wiring method is shown in Chapter 6 Fig 6.5.

## 7.2.2.2 System Operating Strategies of WIT 29.9-50K-XHU

### TOU (Time of use):

Configure the system to work in the preset mode during different time segments based on the peak-valley periods and electricity price. Setting items include: the operating mode, enable/disable AC Charging function (charge from grid). During the time not specifically configured, it will operate according to the system settings.

**Setting** X

**Information**

Device Serial Number: DML2024021    Alias: DML2024021  
Data Logger: JKN0DY60D6    Property: YC1.0/YCaa010198/ZDba-0001/S21B00D00T32P0FU01M012C

**Command**

Time Slot	Mode	Time Range	Mode
<input type="radio"/> Time Slot 1	Load First	00 : 00 ~ 00 : 00	Disable
<input type="radio"/> Time Slot 2	Load First	00 : 00 ~ 00 : 00	Disable
<input type="radio"/> Time Slot 3	Load First	00 : 00 ~ 00 : 00	Disable
<input type="radio"/> Time Slot 4	Load First	00 : 00 ~ 00 : 00	Disable
<input type="radio"/> Time Slot 5	Load First	00 : 00 ~ 00 : 00	Disable
<input checked="" type="radio"/> Time Slot 6	Load First	00 : 00 ~ 00 : 00	Disable

Set Inverter On/Off    Turn On

Please Enter Password    Yes    Advanced Setting    Cancel

### Self-consumption:

The WIT inverter prioritizes supplying the solar power and battery energy to the loads. If Export Limitation is disabled, the surplus solar power can be fed to the grid, but the battery energy will not be exported to the grid; if Export Limitation is enabled, neither solar power nor battery energy would be sent to the grid. In case that the solar power is insufficient, the battery will discharge to power the loads. Priority of power supplied to the loads:

1. Solar panels;
2. Batteries;
3. Grid.

**NOTE:** In Load First mode, a meter is required.

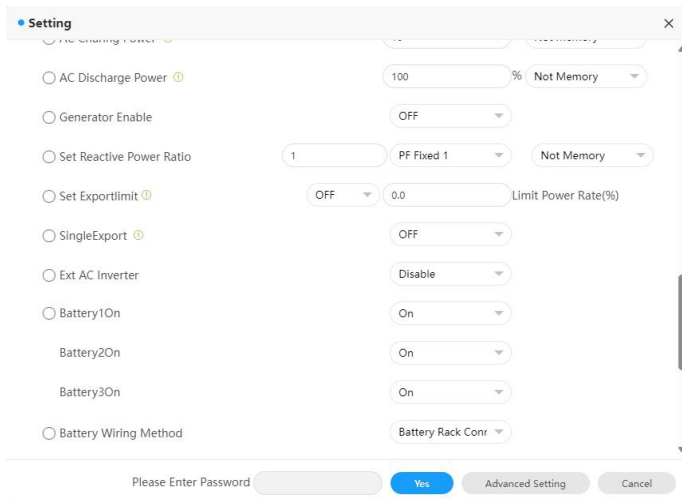

### Grid Peak Shaving:

Set the forward power flow threshold A: once the load power on the external meter is greater than this value, the inverter will reduce charging power and boost power out until it reaches the maximum operating power of the WIT inverter. Set the reverse power flow threshold B: once the grid feed-in power on the external meter is greater than this value, the inverter will reduce output power and boost charging power until it reaches the maximum operating power of the WIT inverter.

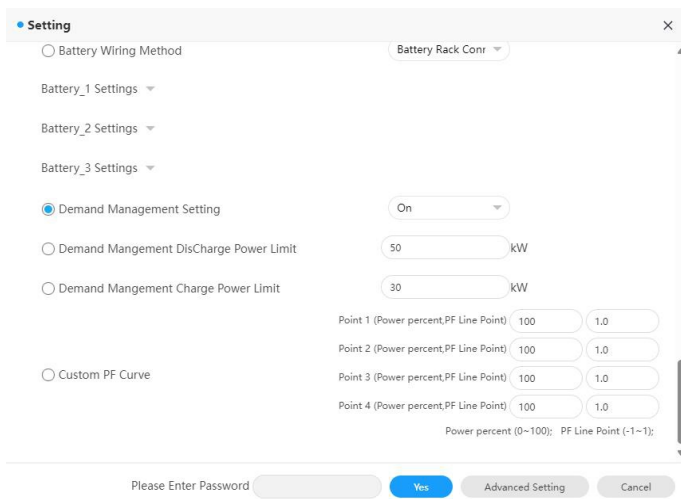

### Micro-grid (PV-ESS-DG Power System):

A generator is connected to the GEN port:

If the grid power is normal, the WIT inverter will work in the grid-tied mode:

1. If the power generated by the grid-tied inverter is sufficient to support the loads, the surplus power will be used to charge the battery;
2. If the power generated by the grid-tied inverter is insufficient, the WIT inverter will supply the solar power to the loads, and direct the surplus power to charge the battery.
3. If the solar power of the WIT inverter is insufficient, the battery will discharge to power the loads.
4. The battery will stop discharging when the SOC is lower than the cutoff threshold and it will draw the grid power to support the loads.

If the grid power is abnormal, the WIT inverter will work in the off-grid mode:

1. The solar power of the WIT inverter is supplied to the loads first, and the surplus power is sent to charge the battery.
2. If the solar power of the WIT inverter is insufficient, the battery will discharge to power the loads.
3. When the battery SOC is lower than the preset diesel generator startup threshold, the DG will start automatically to generate power;
4. If charging from the DG is enabled, the DG will charge the battery.
5. When the battery SOC is higher than the preset diesel generator shutdown threshold, it will disconnect the DG, and shut down the DG.

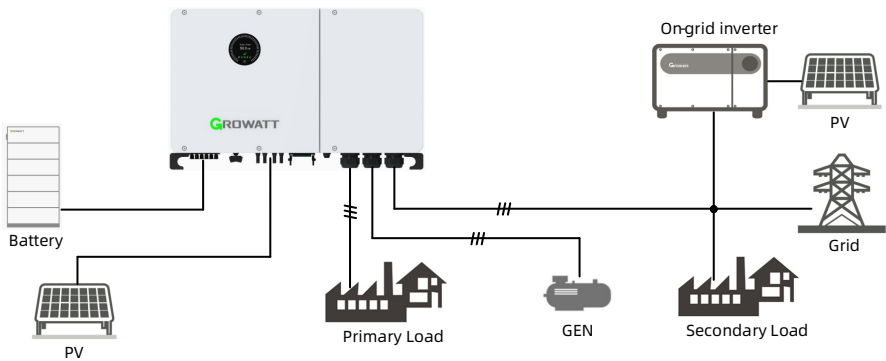

### User-defined dry contact:

After enabling the user-defined DI port and inputting the DI signal, it will carry out the AC active power and power factor according to the corresponding DI instructions.

### Note:

1. The User-defined dry contact and DRMS share the same port.
2. Only one DI signal can be input at the same time.

### 7.2.3 Fault Mode

The intelligent control system of the WIT Inverter monitors and adjusts the system status in real time. When the WIT Inverter detects an alarm, the corresponding status light will turn red and the OLED will display the alarm. When the WIT Inverter detects a fault, the system status indicator and the corresponding status light will turn red and the OLED will display the fault. After the fault or alarm is cleared, the system recovers and all status indicators will be steady green.

**NOTE:** For details about faults and alarms, please see 9.2 Troubleshooting.

### 7.2.4 Shutdown Mode

When the battery SOC is lower than the discharge cutoff SOC and the PV string output power does not meet the requirements for grid-tied power generation, the WIT Inverter will automatically shut down. In shutdown mode, the inverter still consumes a bit energy (PV>Grid>Battery) to wait to start up again when the operating requirements are met.

**NOTE:**

When the PV input voltage is less than 200V or the battery input voltage is less than 200V, the WIT inverter will automatically shut down.

### 7.3 LED and OLED Displays Panel

The LED and OLED display panel demonstrating the running status of the WIT Inverter is shown in the Fig 7.1. The symbol description is shown in Table 7.1; The user interfaces are shown in Fig 7.2, and the LED indicator description is shown in Table 7.2.

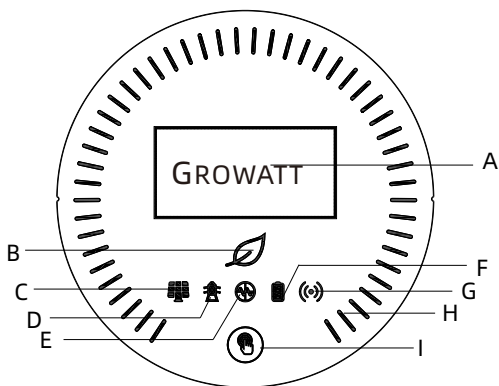
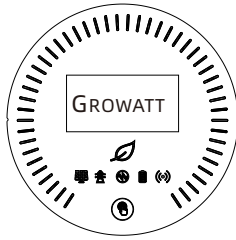

Fig 7.1 Display panel

Table 7.1 Symbol Description

Position	Description	Note
A	OLED screen	Displays the main system information
B	System indicator	Displays the system status
C	PV indicator	Indicates the operation status on the PV side
D	Grid/GEN indicator	indicates the operation status on the grid side and the GEN port status
E	Off-grid indicator	Indicates whether the off-grid mode is enabled
F	Battery indicator	Indicates the status of the battery
G	Communication	Indicates the communication status and other system faults
H	Battery status indicator	Indicates the charging and discharging mode of the battery
I	Button	You can switch the information displayed on the OLED by pressing the button



startup page

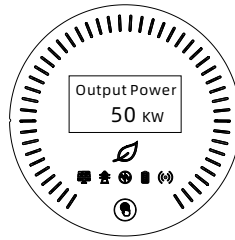

display page

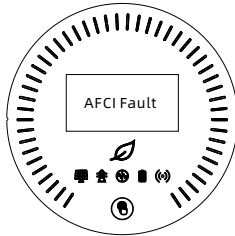

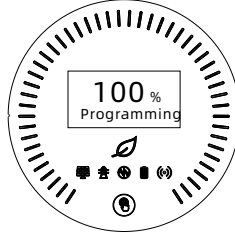

alarm page









update page

Fig 7.2 User interfaces

Table 7.2 Indicator description

	Status	Meaning
	Off	The system is not operating
	Steady green	The system is operating properly
	Blinking green at long intervals	The system is in standby mode or performing an upgrade
	Steady red	System failure
	Off	The PV voltage dose not reach the operating voltage
	Steady green	The PV voltage reaches the operating voltage
	Steady red	A fault or alarm is reported on the PV side
	Off	The grid voltage does not reach the operating voltage or the GEN is nomal
	Steady green	Successfully connected to the grid
	Blinking red at long intervals	A fault or alarm is reported on the GEN side
	Steady red	A fault or alarm is reported on the grid side

	Status	Meaning
	Off	Off-grid mode is disabled
	Steady green	Off-grid mode is enabled and has no faults or alarms
	Steady red	Off-grid mode is enabled and a fault or alarm is reported on the AC side
	Off	The battery voltage is below the operating voltage
	Steady green	SOC of all batteries connected is sufficient; no fault or alarm is raised
	Blinking green at long intervals	Low battery SOC
	Steady red	A fault or alarm is reported on the battery side
	Steady green	External communication is normal, such as RS485, WiLAN, etc.
	Blinking green at long intervals	The WIT Inverter is upgrading or the USB interface is reading and writing data
	Steady red	External communication fails, or a system fault occurs, or the GEN port fails
	Steady white	Battery is in standby mode
	Rotates clockwise	Charging mode
	Rotates anticlockwise	Discharging mode
	Displays critical system information. Users can call up and switch the interface by tapping the button. When a fault or alarm occurs in the system, the fault or alarm will be displayed.	
	The OLED will be activated when the button is pressed. The OLED will turn off if there is no operation for 5 minutes.	

# Monitoring 8

## 8.1 Remote Monitoring

Growatt WIT 29.9-50K-XHU Hybrid inverters support remote monitoring, which can be enabled by installing a datalogger. For more information on operation and configuration methods, see the following link.

Compatible Datalogger	Installation & Operation Guide Linkage
ShineWiLAN-X2	<a href="https://oss-eu.growatt.com/common/knowledgeShareH5No?lang=en&amp;type=159">https://oss-eu.growatt.com/common/knowledgeShareH5No?lang=en&amp;type=159</a>

### 8.1.1 Remote Monitoring on the APP (ShinePhone)



**NOTE:**

- (1) Download and install the latest version of ShinePhone.
- (2) See <https://server-us.growatt.com/?lang=en> for details.

#### Account Registration on ShinePhone

Run the APP and tap “Register” on the login page. Fill in the information as required. Fields marked with \* are mandatory. Tick the checkbox to agree to the Privacy Policy. Once the account is successfully registered, you can log in to the home screen. The registration page is shown below:

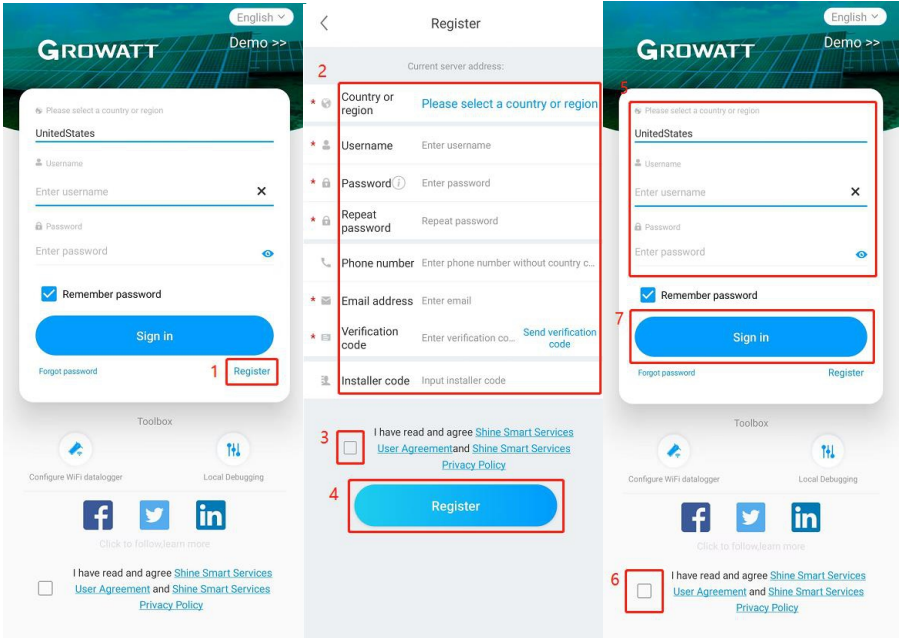

## Home Screen of ShinePhone

Dashboard: displays the critical information of all power plants under the account, such as the total yield, the total revenue and the status of the device. Please refer to the figures below:

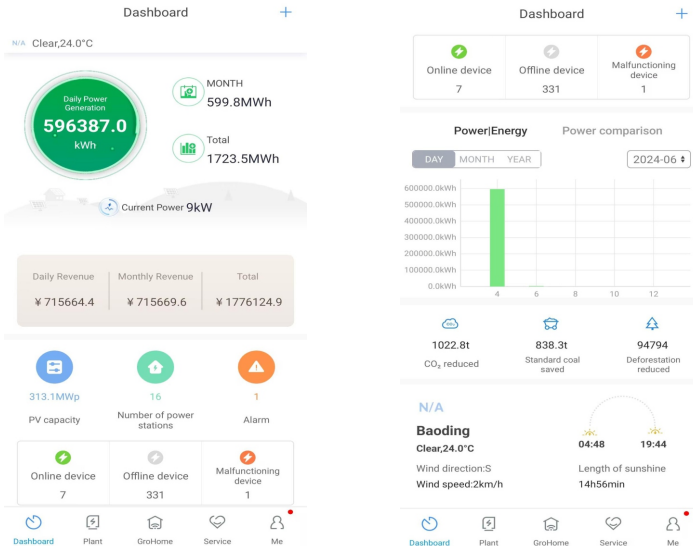

**2. Plant:** displays the plant list and the basic information about each PV plant, as shown in the figure below. You can select your target plant to view detailed information.



**Detail Page of the WIT Inverter:**

To access details about the WIT Inverter or related devices:

- (1) Tap "Plant" and the "Plant List" will be displayed. Select your target plant, then you can access the real-time data and history record of the power plant;
- (2) Select the WIT Inverter marked with its SN from "My device list". The figures below show QWL0DC3008 as an example;
- (3) On the Detail Page, you can view information about the inverter and related devices. Three sections - "Events", "Control" and "Edit", are available at the bottom.

The dashboard displays the following information:

- System Status:** Wait
- Generation Overview:**
  - Today (kWh): 596387.0
  - Generation This Month: 596.4MWh
  - Total: 1194.3MWh
- Power Data:**
  - PPV: 0.0kW
  - Consumption: 0kW
  - Generator power: 0kW
  - Exported to grid: 0.0kW
  - Total power: 0kW
  - Number of batteries: 3
- My device list:**
  - PJN1234666 (Disconnected) - Power: 0W, Today: 0kWh
  - Datalogger\_JKNODY60D6
  - GRT5392728 (Disconnected) - Power: 229379.6W, Today: 347346.2kWh
  - Datalogger\_JKNODY60D6
  - INVERSNERR (Disconnected) - Power: -0.1W, Today: -0.1kWh
  - Datalogger\_JKNODY60D6
- Real-time data:**
  - Current Power: 0.0kW
  - Nominal Power: 50.0kW
  - Consumption: 0kW
  - Import: 0kW
  - Energy Discharged / Day: 0.0kWh
  - Total E-discharged: 0.0kWh
- Generation overview (Today/Total kWh):**
  - Solar production: 0/0
  - System Charged: 0/0
- Environmental Impact:**
  - CO<sub>2</sub> reduced: 477.7t
  - Coal saved: 477.7t
  - Deforestation reduced: 65688

(4) On the “Events” screen, you can view the fault/warning message and suggested trouble-shooting measures.

The Warning list displays the following entries:

- 2024-06-05 15:17:23**
  - SN: PJN1234666
  - Plant name: WIT 30-50K shinephone test
  - (411) Communication fault
- 2024-06-05 09:50:02**
  - SN: PJN1234666
  - Plant name: WIT 30-50K shinephone test
  - (105)
- 2024-06-05 09:19:11**
  - SN: PJN1234666
  - Plant name: WIT 30-50K shinephone test
  - (411) Communication fault
- 2024-06-04 10:08:37**
  - SN: PJN1234666
  - Plant name: WIT 30-50K shinephone test
  - (411) Communication fault

No more data

(5) On the “Control” screen, you can configure the WIT Inverter. The password is in the format of “growatt + the current date”, e.g. growatt20240228.

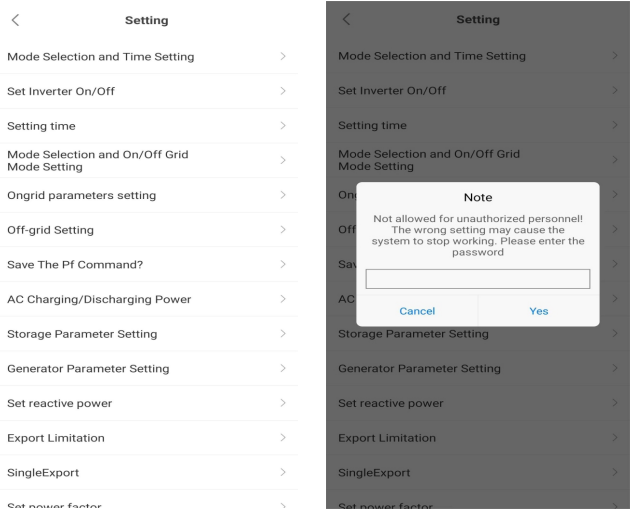

➤ **Set Working Modes for Different Time Periods**

Tap Control > Mode Selection and Time Setting; 6 time segments are configurable. You can set the start and end time of each period, the corresponding working mode, including Load First, Battery First and Grid First, and whether to enable/disable the selected working mode. Choose the appropriate working mode considering the corresponding electricity rates and power consumption during the specific time period.

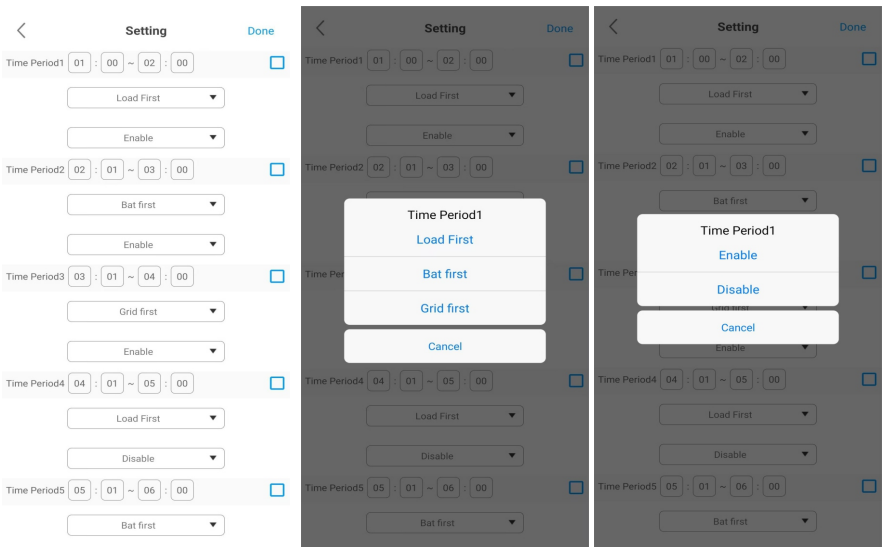

➤ **Set Inverter On/Off**

Tap Control > Set Inverter On/Off; you can power on/off the inverter, as the figure shows.

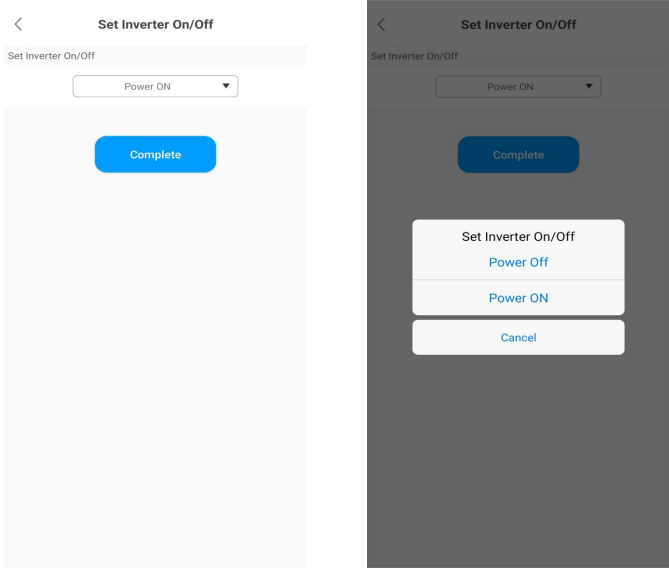

➤ **Set the Time of the Inverter**

Tap Control > Setting Time; you can set the local time, as the figure shows.

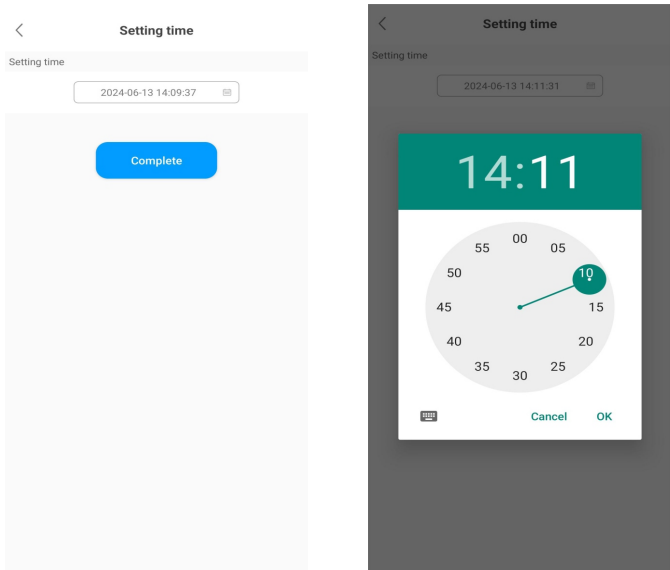

➤ **Set the Mode Transfer and the On-/Off-grid/GEN Mode**

Tap Control > Mode Transfer and On- /Off-grid/GEN Mode setting. Two options are available: Automatic mode and Manual mode. If the Manual mode is selected, you can set the inverter to work in the on- /off-grid, or generator mode, as the figure shows. The Automatic Mode is recommended.

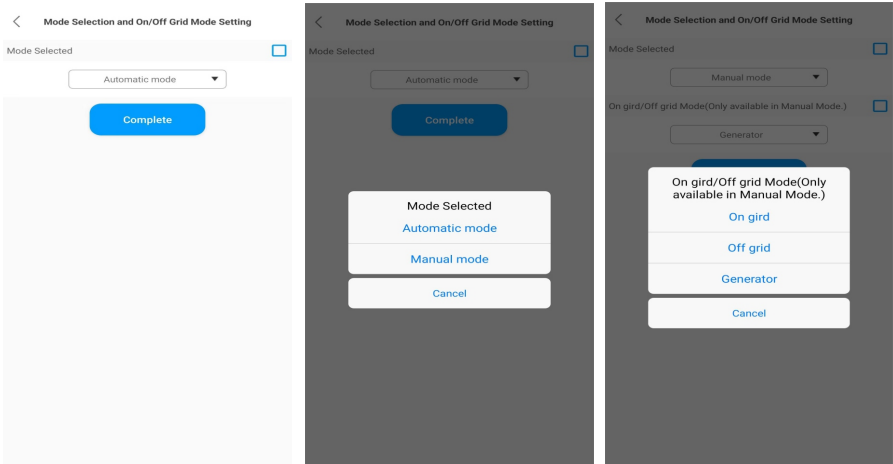

➤ **Set the Grid Parameters**

Tap Control > On-Grid parameters setting, you can set the voltage upper/lower threshold of grid connection and the frequency upper/lower threshold of grid connection, as the figure shows.

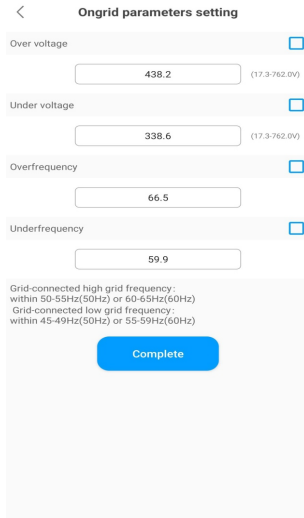

➤ **Set the Off-grid Parameters**

Tap Control > Off-grid Setting, you can enable/disable the off-grid mode, set the off-grid frequency (50Hz/60Hz) and the off-grid voltage (220V/230V/ 240V /277V/127V), complying with the safety regulations.

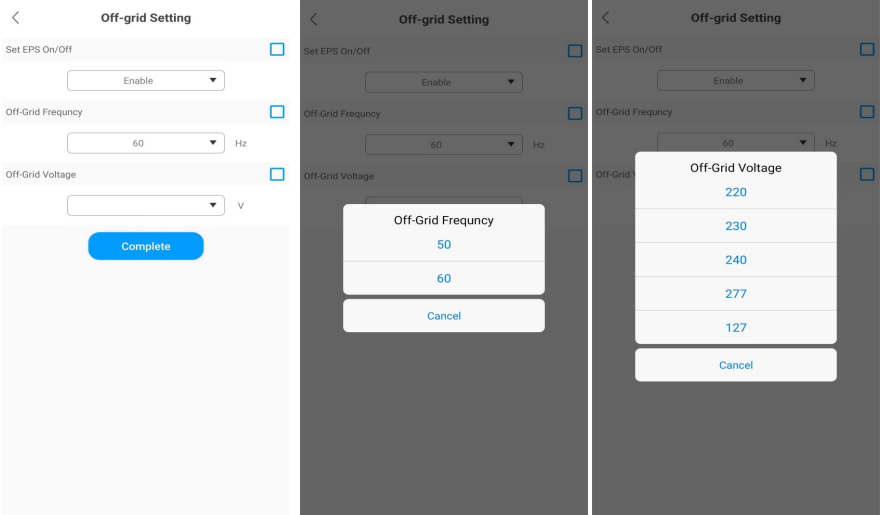

➤ **Set Whether to Apply the Following PF Command**

Tap Control > Save the Pf command, you can select whether to apply the following PF command, as the figure shows.

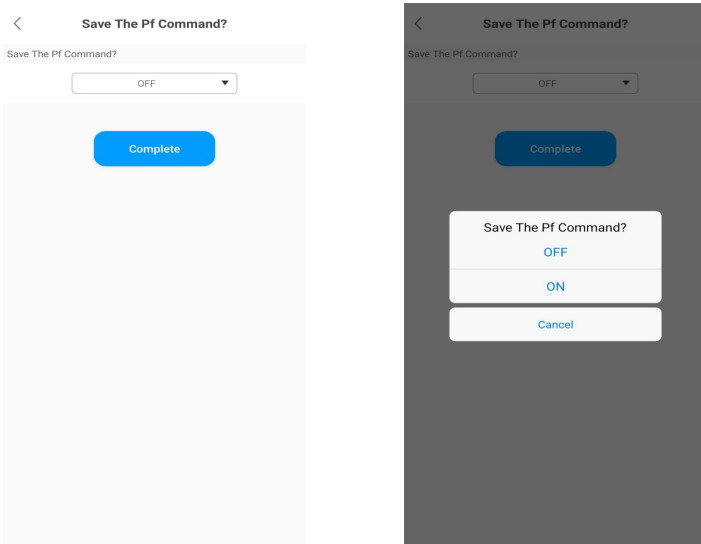

➤ **Set AC Charging and Discharging Power**

Tap Control > AC Charging /Discharging Power, you can configure the AC charging/discharging power and choose whether to remember your settings, as the figure shows.

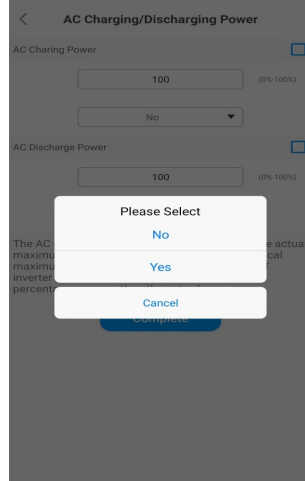
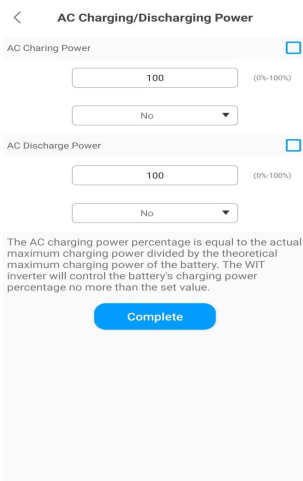

➤ **Set the Storage Parameters**

Tap Control > Storage Parameter Setting, you can enable/disable the AC charging function (Charge from grid), the charging cutoff SOC (100 is recommended) and the discharging cutoff SOC (10 is recommended), as the figure shows.

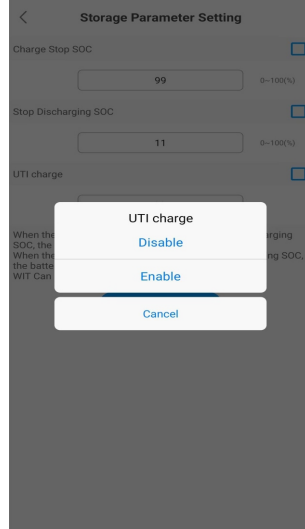
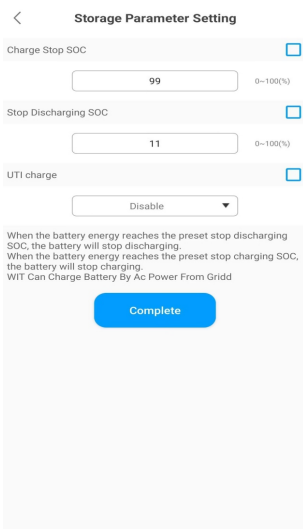

➤ **Set the Generator Parameters**

Tap Control > Generator Parameter Setting, you can enable/disable the Generator function, set the Generator Start/Stop SOC and the Generator power, as the figure shows.

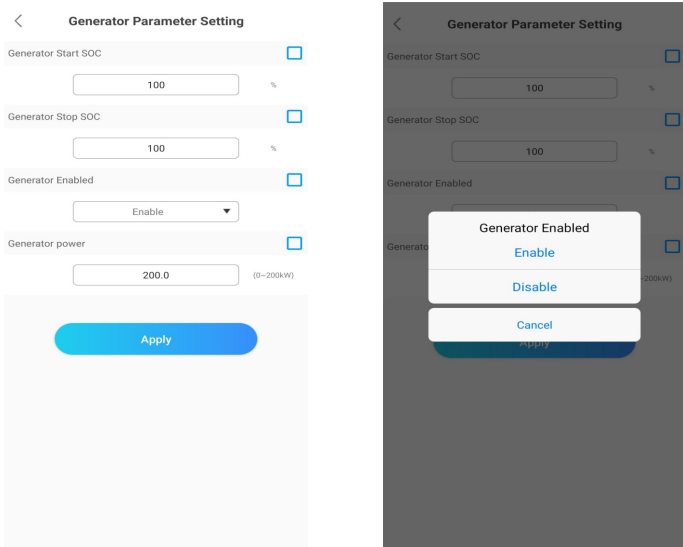

➤ **Set the Reactive Power**

Tap Control > Set reactive power, you can select the corresponding PF mode and whether to remember your settings, as the figure shows.

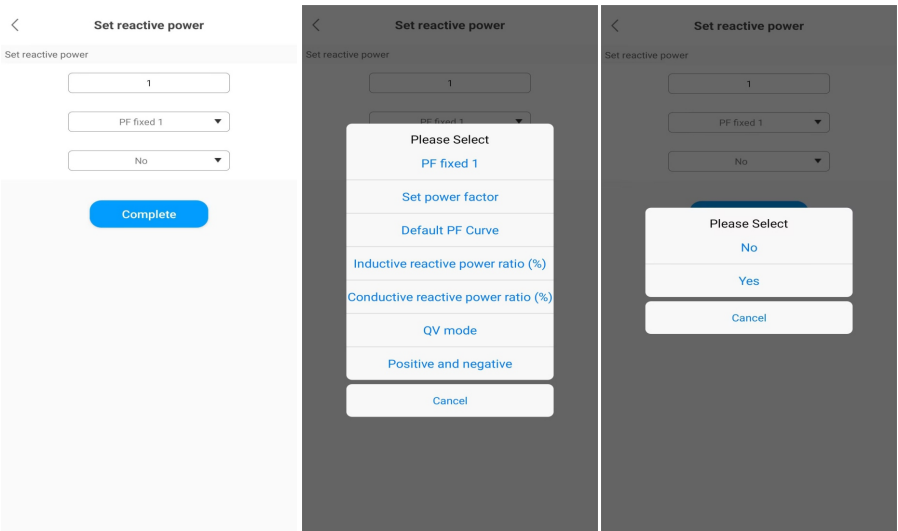

➤ **Set the Export Limitation Parameters**

Tap Control > Export Limitation, you can enable/disable the export limitation function according to local regulations. If the Export Limitation function is enabled, you can set the Export power limit, as the figure shows.

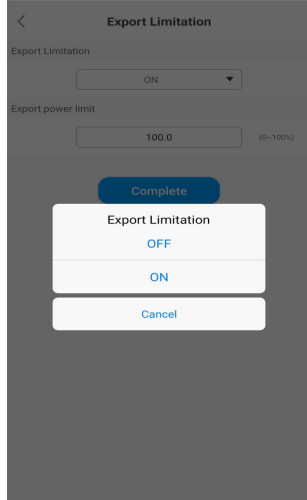
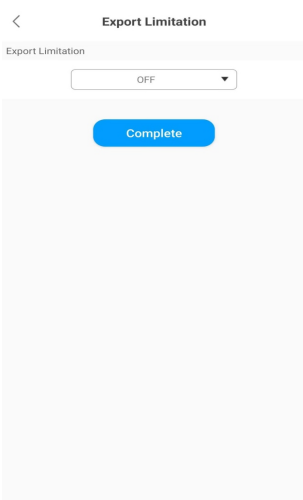

➤ **Set the Single-phase Export Limitation**

Tap Control > Single Export, you can enable/disable the single-phase export limitation function, as the figure shows.

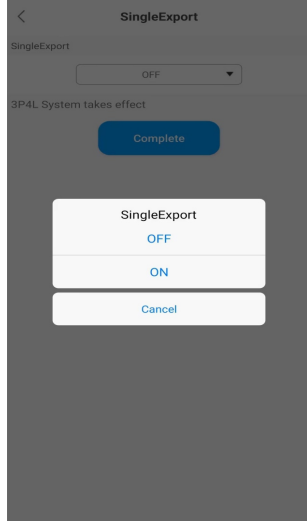
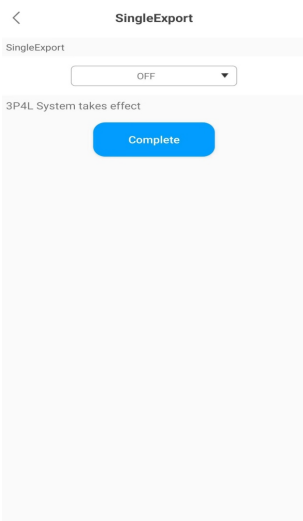

➤ **Set the Power Factor**

Tap Control > Set power factor, you can set the PF value, ranging from -1 to 1, as the figure shows.

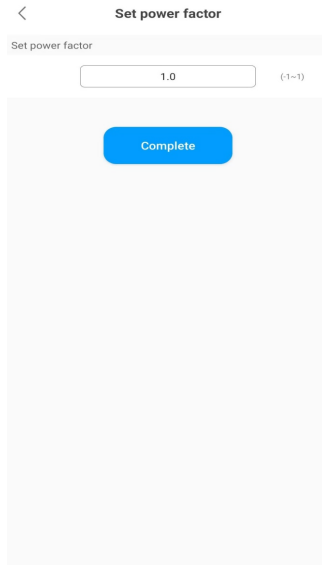

➤ **Set the Device Type of GEN Port**

Tap Control > Device Type of GEN port: you can set the device type connected to the GEN port: Generator, PV Inverter, or Smart Load, as the figure shows.

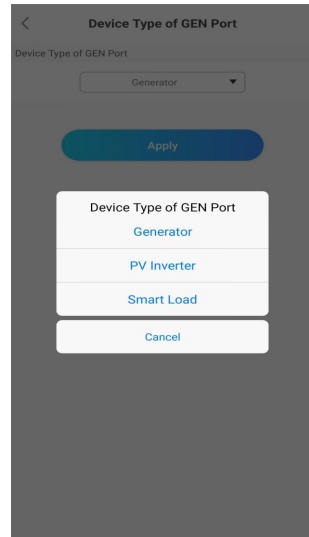
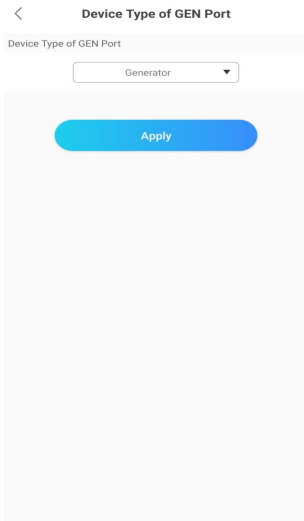

➤ **Set the Battery Wiring Method**

Tap Control > Battery Wiring Method, you can set the wiring between the inverter and the battery: three battery clusters are connected to the three ports respectively, or one battery cluster is connected to the three ports.

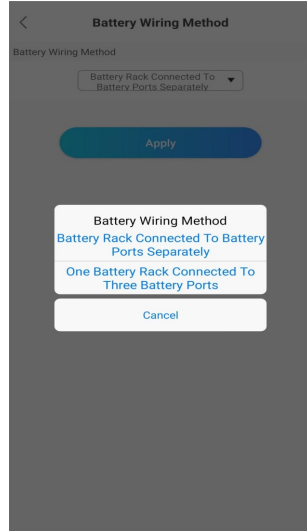
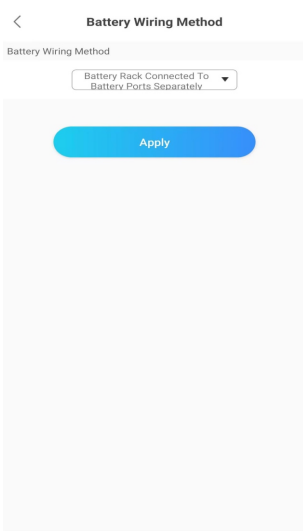

➤ **Set the AC Couple Parameters**

Tap Control > AC Couple Parameter Setting, you can enable/disable the AC Couple function and set the AC Couple Starts/Stops SOC, as the figure shows.

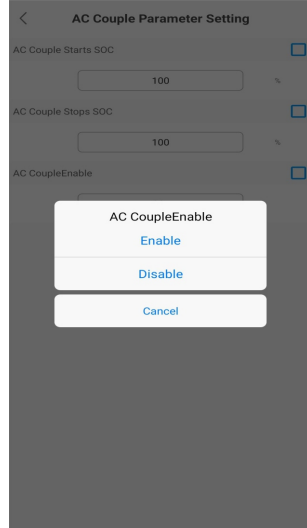
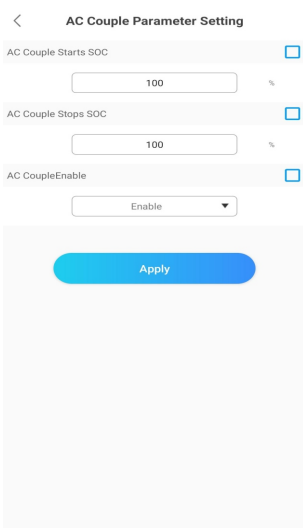

### ➤ Set the Battery Enable

Tap Control > Battery Enable, you can enable/disable Battery\_1, Battery\_2 and Battery\_3, as the figure shows.

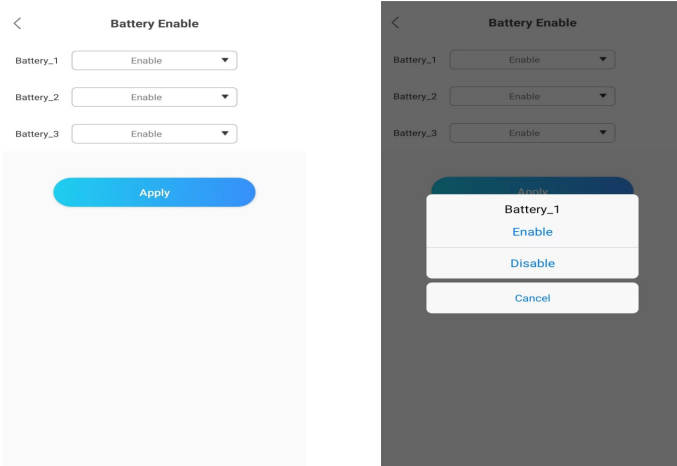

### ➤ Set the Battery\_1/Battery\_2/Battery\_3

Tap Control > Battery\_1/Battery\_2/Battery\_3 Settings, you can set the Battery-related parameters (the battery capacity, ranging from 0 to 2000Ah; the maximum charging/discharging power, ranging from 0 to 200kw; the maximum charging/discharging current, ranging from 0 to 200A; the battery maximum charging voltage, ranging from 200 V to 900V; the battery discharge cutoff voltage, ranging from 200 V to 900V), as the figure shows.

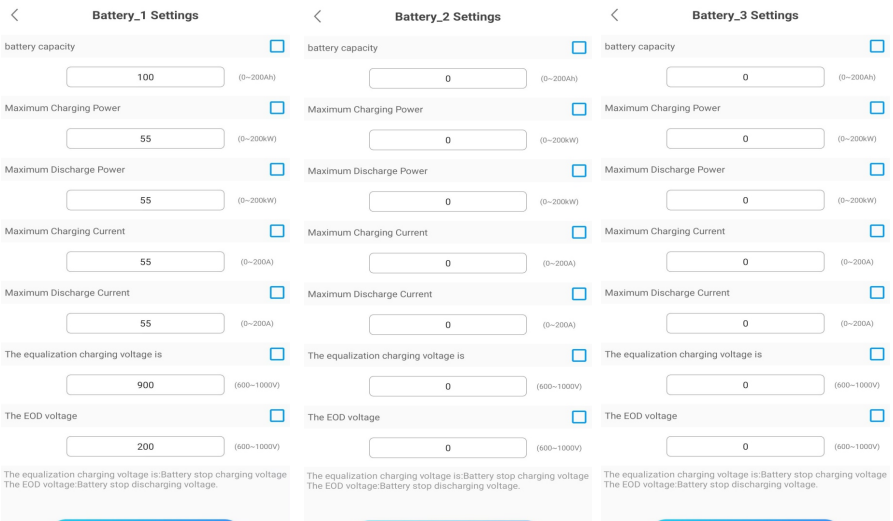

➤ **Set the Customized PF Curve**

Tap Control > Customize PF curve, you can set the power percentage and the power factor of each point, as the figure shows.

< **Customize PF curve**

Point1

Power percentage  (%)

Power factor point

Point2

Power percentage  (%)

Power factor point

Point3

Power percentage  (%)

Power factor point

Point4

Power percentage  (%)

Power factor point

Power percentage(0~100)  
Power factor point(-1~1)

**Complete**

(6) **Edit:** you can change the device name as the figure shows.

< **Edit** [Save](#)

Alias PjN1234666 >

**Delete**

3. **GroHome**: displays the home energy system, including four sections: "PV linkage", "My device list", "My room" and "My scene".

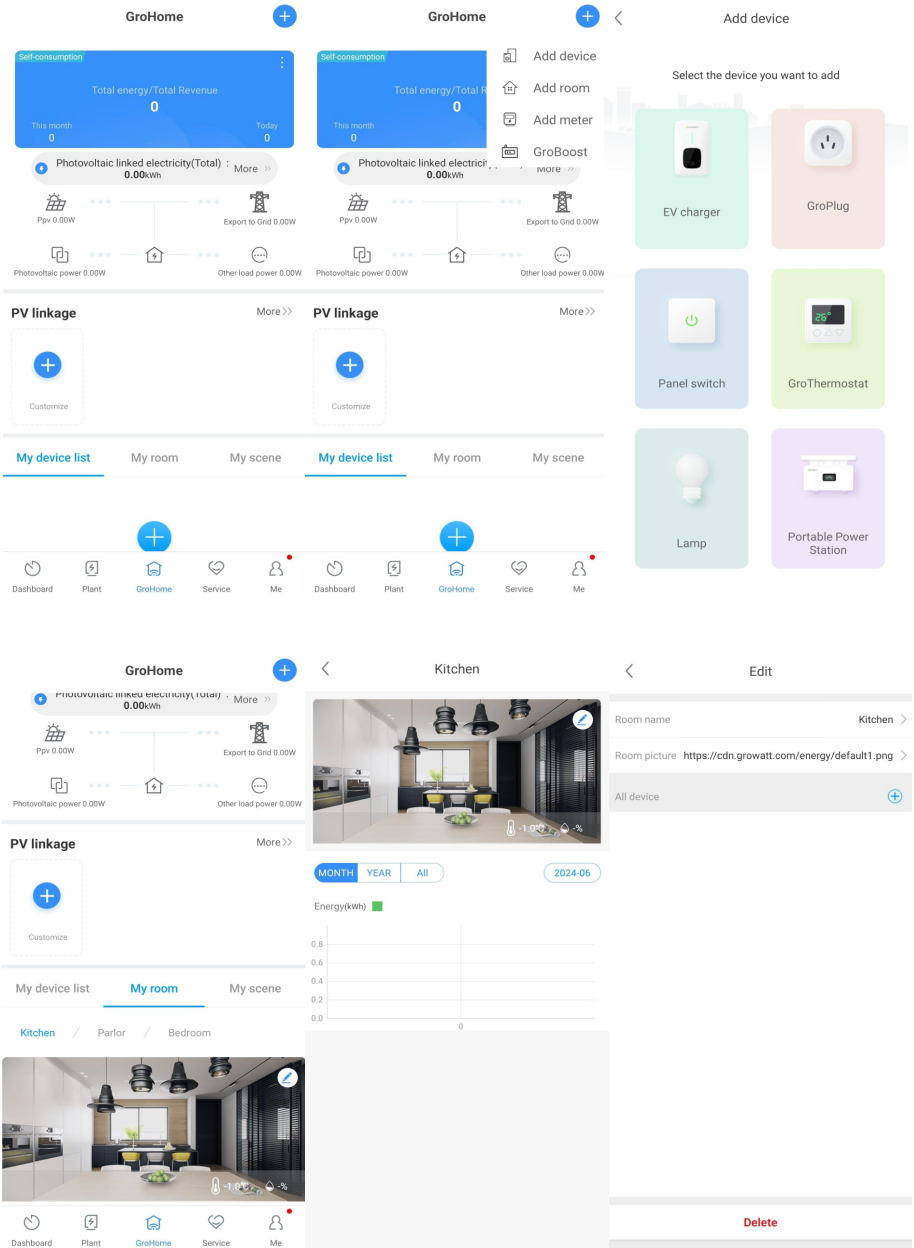

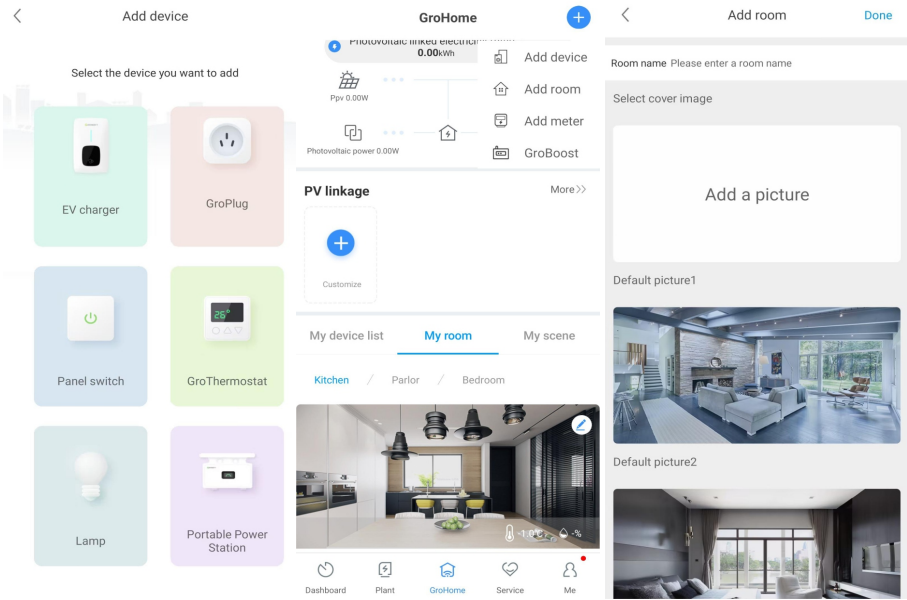

4. **Service:** includes the common faults and troubleshooting suggestions, as shown in the figure below. Should you encounter any problem about our product, you can contact the Growatt after-sales support or refer to the related documents.

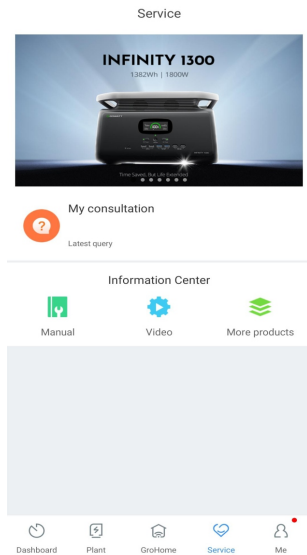

5. Me: You can check the account information, configure the datalogger or view notifications, as shown in the figure below.

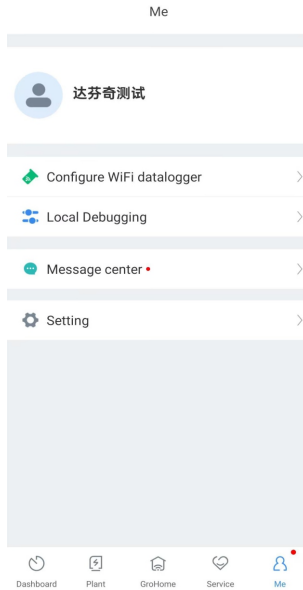

### 8.1.2 Remote Monitoring on the ShineServer Webpage

1. Open the browser, then enter <https://server.growatt.com/login?lang=en> in the address box to access the login page. Click "Register an Account" if you do not have an account.

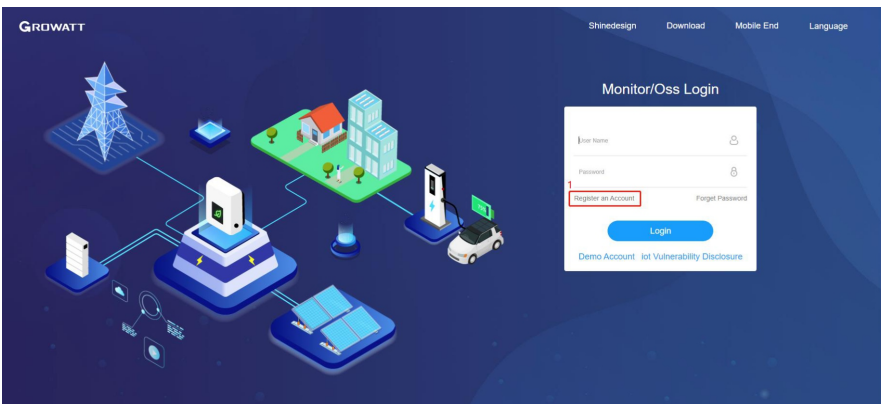

2. After the Registration Page is displayed, fill in the information as required and click to agree to the Privacy Policy. Fields marked with the “. ” icon are mandatory. Click next, it will bring you to the “Add Plant” page. Then click “Back to Login” on the top right corner.

The screenshot shows the GROWATT Register page with the 'User' tab selected. The form includes fields for Country, User Name, Password, Confirm Password, Language, Phone Number, and E-Mail. There are checkboxes for 'Allow Remote Operation and Maintenance' for both Installer and Distributor roles. A red box highlights the 'I have read and agree to the (User Agreement) (Privacy Policy)' checkbox, and a blue 'Next' button is visible below it.

This screenshot is identical to the one above, showing the GROWATT Register page with the 'User' tab selected. In this version, a red box highlights the 'Back to Login' link in the top right corner of the page header.

3. On the Login screen, enter the username and the password to log in to the home screen.

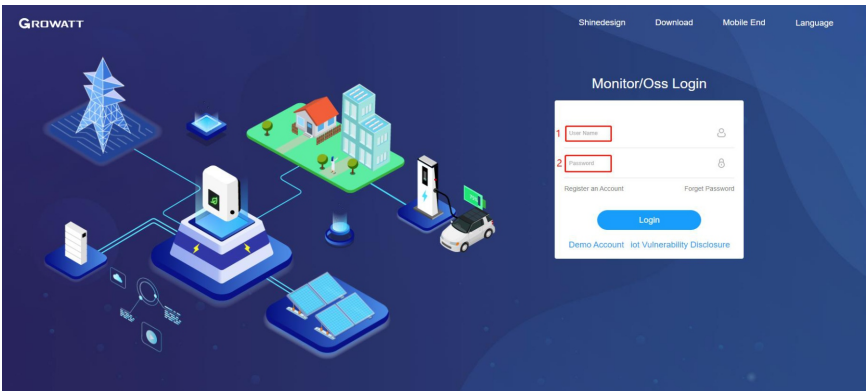

4. After accessing the home screen, the “Add Plant” window will pop up. Fill in the information as required (marked with “-”) and click “Yes”. If the plant has been created, you can select the target plant on the home screen.

● Add Plant
✕

**Installation Information**

Plant Name  Installation Date  PV Total Capacity(kWp)  Installer

Plant Type Residential Plant Temperature type  Centigrade(°C)  Fahrenheit(°F)

**Location Information**

Country Please Select City  Address

Time Zone UTC -12 Longitude  Latitude

Plant Image  Microinverter Installation Map

Only support JPG, PNG, JPEG, BMP; the size of no more than 5M

**Set Revenue Formula(Set 1KWh As The Conversion Standard)**

<div style="background-color: #f0f0f0; padding: 5px; border-bottom: 1px solid #ccc;"> <span style="font-size: 12px;">☁ Total Generation</span> </div> <div style="font-size: 24px; font-weight: bold;">1.7(GWh)</div>	<div style="background-color: #f0f0f0; padding: 5px; border-bottom: 1px solid #ccc;"> <span style="font-size: 12px;">☁ PV Total Capacity</span> </div> <div style="font-size: 24px; font-weight: bold;">312100.0(kWp)</div>	<div style="background-color: #f0f0f0; padding: 5px; border-bottom: 1px solid #ccc;"> <span style="font-size: 12px;">💰 Total Revenue</span> </div> <div style="font-size: 24px; font-weight: bold;">1776124.88(¥)</div>
---	---	---

All Plants
Residential Plant
Commercial Plant
Ground-Mounted Plants
● Online
● Abnormal
● Offline
Power Station Sequencing
Real-time Power Priority
Please Enter Plant Name 🔍

<div style="background-color: #f0f0f0; padding: 5px; border-bottom: 1px solid #ccc;"> <span style="font-size: 12px;">● WIT 30-50K shinephone test</span> </div> <div style="font-size: 18px; font-weight: bold;">596.4MWh</div> <div style="font-size: 12px;">Generation Today</div> <div style="font-size: 18px; font-weight: bold;">0.02kW</div> <div style="font-size: 12px;">Real-time Power</div>	<div style="background-color: #f0f0f0; padding: 5px; border-bottom: 1px solid #ccc;"> <span style="font-size: 12px;">●</span> </div> <div style="font-size: 18px; font-weight: bold;">1kWh</div> <div style="font-size: 12px;">Generation Today</div> <div style="font-size: 18px; font-weight: bold;">0kW</div> <div style="font-size: 12px;">Real-time Power</div>	<div style="background-color: #f0f0f0; padding: 5px; border-bottom: 1px solid #ccc;"> <span style="font-size: 12px;">●</span> </div> <div style="font-size: 18px; font-weight: bold;">0kWh</div> <div style="font-size: 12px;">Generation Today</div> <div style="font-size: 18px; font-weight: bold;">0kW</div> <div style="font-size: 12px;">Real-time Power</div>	<div style="background-color: #f0f0f0; padding: 5px; border-bottom: 1px solid #ccc;"> <span style="font-size: 12px;">●</span> </div> <div style="font-size: 18px; font-weight: bold;">0kWh</div> <div style="font-size: 12px;">Generation Today</div> <div style="font-size: 18px; font-weight: bold;">0kW</div> <div style="font-size: 12px;">Real-time Power</div>	<div style="background-color: #f0f0f0; padding: 5px; border-bottom: 1px solid #ccc;"> <span style="font-size: 12px;">●</span> </div> <div style="font-size: 18px; font-weight: bold;">0kWh</div> <div style="font-size: 12px;">Generation Today</div> <div style="font-size: 18px; font-weight: bold;">0kW</div> <div style="font-size: 12px;">Real-time Power</div>
--	--	--	--	--

5. Click the target plant and the detailed page will be displayed, click “Add Data Logger” on the upper right corner to add the datalogger connected to the inverter.

  - 1) Enter the serial number (SN) of the datalogger
  - 2) Select the target power plant. You might need to enter the verification code of the datalogger as prompted.

The screenshot shows the GROWATT Energy management interface. At the top, there are navigation tabs: Dashboard, Energy (selected), Home energy, Log, and Setting. The main content area is titled 'Energy' and shows 'Current Location: Energy > Plant Management'. Below this, there is a 'Plant Management' section with a search bar and an 'Add Plant' button. A table lists 10 plants with columns for No., Plant Name, Country, City, Installation Date, Time Zone, PV Total Capacity (kWp), Total Power Generation (kWh), and Operations. The 'Add Data Logger' button is highlighted with a red box in the top right corner of the dashboard.

No.	Plant Name	Country	City	Installation Date	Time Zone	PV Total Capacity(kWp)	Total Power Generation(kWh)	Operations
1	测试	China	深圳	2022-08-22	8	8000	243419.5	
2	WIT 惠州增城双坑站	China	惠州	2023-04-14	8	100	240353.3	
3	惠州WIFI-X2	China	深圳	2023-05-04	8	3000	0	
4	深圳博罗站	China		2023-06-07	8	100000	7715.7	
5	惠州惠化站	China	惠州	2023-10-10	8	1000	36570.3	
6	测试设备_为测	China		2023-08-11	8	100000	0	
7	多行高压逆变器	China		2023-08-17	8	100000	0.8	
8	55M储能电站	China		2023-08-19	8	0	0	
9	测试数据站20231012	China		2023-10-12	8	0	0	
10	WIT 30-50K shinephone test	United States	UnitedStates	2023-10-23	8	0	119419.75	

The screenshot shows a modal dialog box titled 'Add Data Logger'. It contains two input fields: 'Data Logger SN' with a text input field and a red dot, and 'Assigned Plant' with a dropdown menu showing 'WIT 30-50K shine' and a red dot. At the bottom, there are two buttons: 'Yes' (blue) and 'Cancel' (grey).

6. After adding the datalogger successfully, you can click Dashboard to view details about related devices.

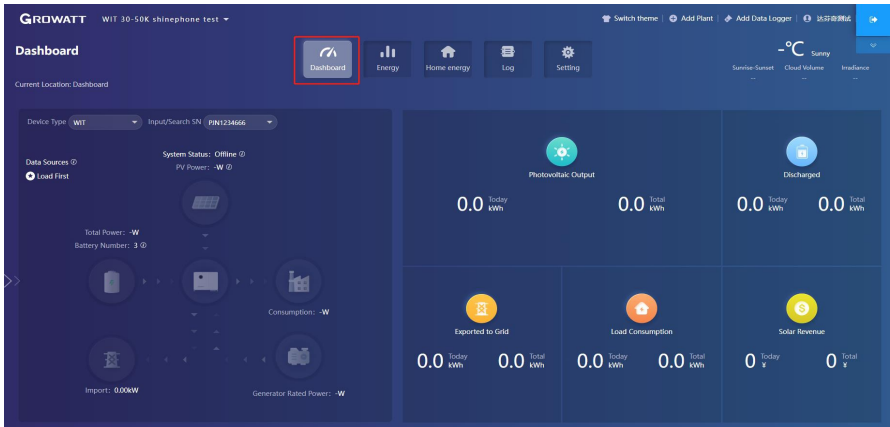

## Dashboard:

### 1. Running status and energy display

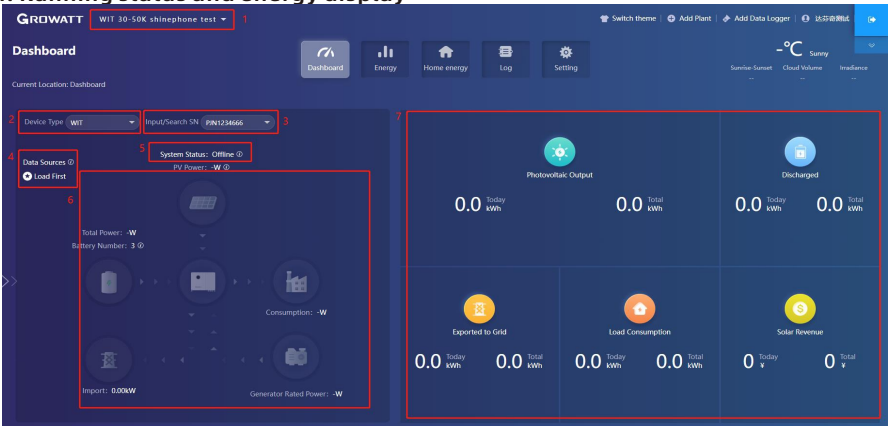

- 1) Plant List: select the target plant from the drop-down list
- 2) Device Type: Select the device from the drop-down list
- 3) Input/Search Number: Upon the initial search, enter the serial number of the specific device; If you have searched for it before, you can select the device from the drop-down list
- 4) Data Sources: displays the data source of the selected device: Load First, Battery First and Grid first
- 5) System Status: displays the running status of the selected device: operating, faulty, standby and off-line
- 6) System Running Graph: displays the power flow between the PV modules, the battery, the generator and the AC side
- 7) Energy: displays today's/total PV generation, power imported from grid, power exported to the grid and the load consumption

## 2. Energy Trend

- 1) System Production: displays the power for self-consumption and the power exported to the grid
- 2) Date: select a specific date, you can view the energy data in a specific period, day, month or year
- 3) Load Consumption: displays the power for self-consumption and the power drawn from the grid
- 4) Display options: to show/hide the content by clicking the corresponding color circle. By placing the cursor on the specific color circle for a long period, it will display the energy trend of the selected item only

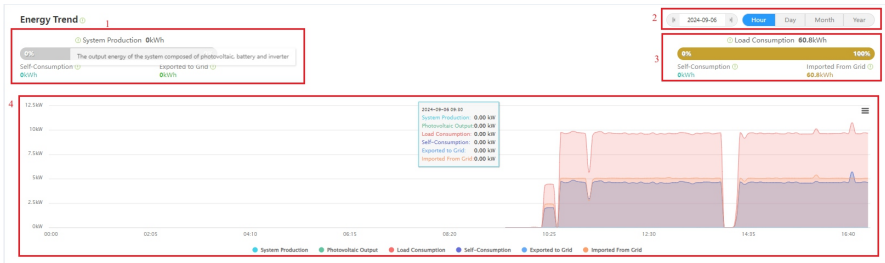

## 3. Battery Information

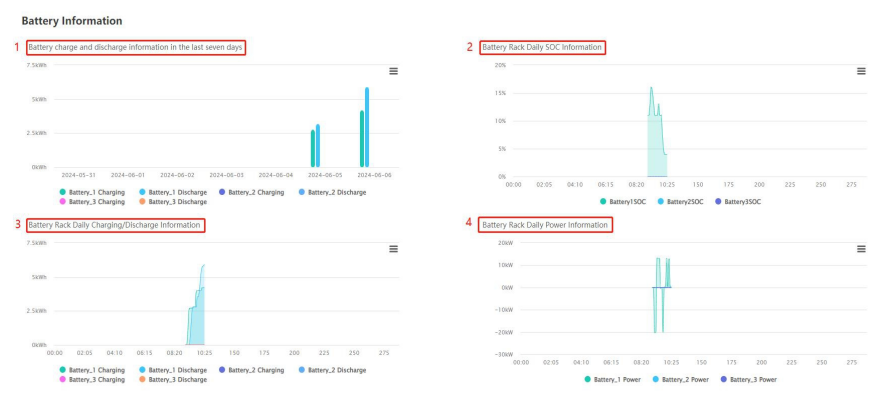

- 1) Battery charge and discharge information over the last seven days: it can display the charge and discharge history of the battery clusters over the past seven days.
- 2) Battery rack daily SOC information: displays the battery SOC.
- 3) Battery rack daily charge/discharge information: displays the charging and discharging information of the battery cluster on the current day.
- 4) Battery rack daily power information: it can display the power of the battery cluster on the current day.

## 4. My PV devices

This section displays all devices involved in the selected PV plant (online devices are shown first, followed by offline devices).

### Energy

#### 1. Parameter comparison

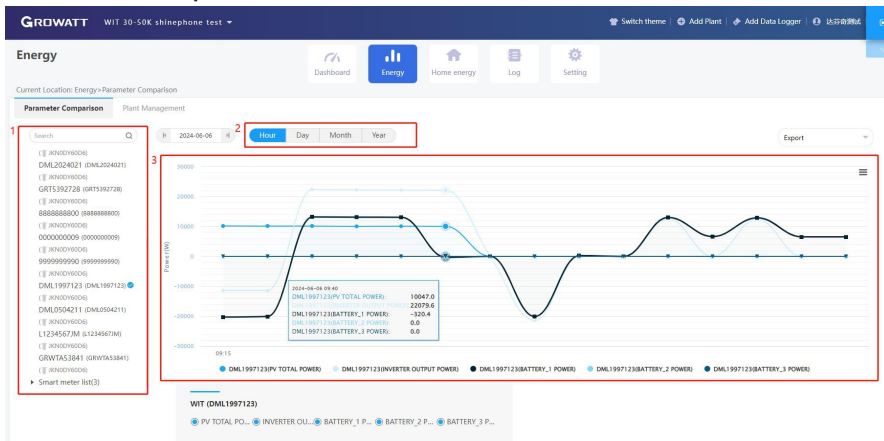

- 1) Device type: Select the device type for comparison, such as the WIT inverter or the meter
- 2) Date: select a specific date, you can view the energy data in a specific period, day, month or year.

#### 2. Plant Management

Plant Management

Plant Name WIT 30-SDK shingone Search Add Plant

No.	Plant Name	Country	City	Installation Date	Time Zone	PV Total Capacity(Wp)	Total Power Generation(Wh)	Operations
1	WIT 30-SDK shingone test	United States	UnitedStates	2023-10-23	8	0	1194319.75	1 2 3

Total 1 item Previous 1 Next To First 1 Page Yes

Click Plant Management and you can view all PV plants associated with the current account.

- 1) Edit: Click the “Edit” icon (indicated in the figure above) to modify the PV plant information
- 2) Delete: Click the “Delete” icon (indicated in the figure above) to delete the selected PV plant
- 3) Data: Click the “Data” icon (indicated in the figure above) to view the energy yield and power of the selected plant

## Log

On the Log page, you can view the error code and the fault description.

Log

Current Location: Log-Fault Log

Fault Log APPID: 2024-06-05

Device Serial Number	Alias	Battery Serial Number	Device Type	Time	Event Number	Fault Description	Solution
DML1997123	DML1997123		Wls	2024-06-05 20:48:54	302	No AC Connection	1.After shutdown,Check AC wiring. 2.If error message still exists,contact manufacturer.
RIN1234666	RIN1234666		Wls	2024-06-05 15:17:23	411	Communication fault	1.After shutdown,Check communication board wiring. 2.If the error message still exists, contact manufacturer.
RIN1234666	RIN1234666		Wls	2024-06-05 09:50:02			
RIN1234666	RIN1234666		Wls	2024-06-05 06:19:11	411	Communication fault	1.After shutdown,Check communication board wiring. 2.If the error message still exists, contact manufacturer.

## Setting

### 1. Account management

Setting

Current Location: Settings>Account Management

Account Management Visitor Account list E-mail Setting Download Monitor Settings

1 **UserInfo Modify** (Please develop the information so that we can better serve you.)

2 **Modify Password**

User Name: 谷江江江江

Company Name:

Real Name:

E-mail: aabakujahong@growatt.com

Phone Number: 1234567890

Language: 中文

Agent Code:  Agent Code or Alias:  Modify

API Secret Key token:  Modify

Current Password:

New Password:

Confirm Password:

Save

1) Modify your account information

2) Change the password: you can change the password on this page

### 2. Download

A range of documents are available for download.

Setting

Current Location: Settings>Download

Account Management Visitor Account list E-mail Setting **Download** Monitor Settings

Document Download

No.	File Name	File Type	File Size	Update Time	Download
1	ShineServer user manual	pdf	4.11MB	2015-03-21	中文 English
2	Growatt ShineWiFi user manual(中文/英文/德/法/俄/印地语)	pdf	4.33MB	2016-08-18	中文 English
3	Growatt Shine3S ShineSPECS user manual(中文/英文/德/法/俄/印地语)	pdf	3.72MB	2016-08-18	中文 English
4	Android Growatt APP Module	apk	0.26M	2016-01-25	中文 English
5	iOS Growatt APP Module	apk	0.26M	2016-01-25	中文 English
6	Growatt CH4 WiFi Update Module	apk	0.46M	2016-04-25	中文 English
7	Growatt Webbox Update Module	apk	0.46M	2016-04-25	中文 English
8	Growatt Webbox Instructions	pdf	1.27MB	2017-07-20	English
9	Growatt Datalog WiFi ShineWiFi-S Instructions	pdf	1.81MB	2020-04-21	English
10	Microinverter Installation Map	pdf	442KB	2023-11-13	English

Copyright©2019 - SHENZHEN GROWATT NEW ENERGY TECHNOLOGY Co., Ltd. (ShineServer 2.8.0.0)

# Device

## 1. Datalogger

The screenshot displays the 'Device' management page for a 'Photovoltaic Device'. It features a top navigation bar with 'GROWATT WIT 30-50K shinephone test' and utility icons. Below the navigation are summary cards for Power (0 Current, 685 Rated), Generation (596387 Today, 596391.3 This Month, 1194319.7 Total), and Revenue (715664.4 Today, 715669.6 This Month, 1433183.8 Total). The 'Data Logger' section is active, showing a list of devices. The first device, JKN0DY60D6, is highlighted with red boxes and numbered 1 through 10, corresponding to the numbered list items below. The second device, JKN0DY60CT, is shown below it with its details.

- 1) Serial number: each datalogger has a specific SN, which can be used to search for the device
- 2) User name and the PV plant to which the datalogger is connected;
- 3) Connection status: connected or disconnected;
- 4) Data update interval;
- 5) Update time;
- 6) Device type;
- 7) Firmware version;
- 8) Enter the serial number to search for the target datalogger;
- 9) Add a datalogger: enter the serial number to add the datalogger;
- 10) Datalogger settings: you can set the update time for the datalogger

## 2. WIT

The screenshot displays the 'Device' management page for a 'Photovoltaic Device' with the 'WIT' tab selected. It features the same summary cards as the previous screenshot. The 'Data Logger' section shows a list of WIT devices. The first device, WIT-H1HEJHU, is highlighted with red boxes and numbered 1 through 10, corresponding to the numbered list items below. The second device, also WIT-H1HEJHU, is shown below it with its details.

- 1) Enter the serial number to find the device;
- 2) Device model;
- 3) User name and the PV plant to which the device is connected;
- 4) Daily and monthly energy yield;
- 5) Serial number of the selected device;
- 6) Operating status: operating, standby, disconnected or faulty;
- 7) Serial number of the datalogger connected to the device;
- 8) Rated power;
- 9) Current power;
- 10) Parameter settings.
- 10.1) Set the working mode and the time period

● Setting
✕

---

**Information**

Device Serial Number: PJN1234666    Alias:

Data Logger: JKN0DY60D6    Property: YC1.0/YCAAxxxxxx/ZDba-0002/S21B00D00T00P0FU01M01F4

---

**Command**

<input type="radio"/> Time Slot 1	<span style="border: 1px solid red; padding: 2px;">Load First</span>	<span style="border: 1px solid red; padding: 2px;">01 : 00 ~ 02 : 00</span>	<span style="border: 1px solid red; padding: 2px;">Enable</span>
<input type="radio"/> Time Slot 2	Battery First	02 : 01 ~ 03 : 00	Enable
<input type="radio"/> Time Slot 3	Grid First	03 : 01 ~ 04 : 00	Enable
<input type="radio"/> Time Slot 4	Load First	04 : 01 ~ 05 : 00	Disable
<input type="radio"/> Time Slot 5	Battery First	05 : 01 ~ 06 : 00	Enable
<input type="radio"/> Time Slot 6	Grid First	06 : 01 ~ 23 : 00	Enable
<input type="radio"/> Set Inverter On/Off		Turn On	

Please Enter Password
20240613
Yes
Advanced Setting
Cancel

### 10.2) Powering on/off the device: you can power on/off the device remotely

The screenshot shows the 'Setting' menu with the following items:

- Time Slot 4: Load First, 04:01 ~ 05:00, Disable
- Time Slot 5: Battery First, 05:01 ~ 06:00, Enable
- Time Slot 6: Grid First, 06:01 ~ 23:00, Enable
- Set Inverter On/Off**: Turn On (dropdown menu open showing Turn On and Shut Down)
- Set Time
- Grid recovery reconnection wait time: 0~5000S
- Mode Switch: Automatic
- High Grid Voltage Limit: 438.2 (17.3~762V)
- Low Grid Voltage Limit: 338.6 (17.3~762V)
- High Grid Frequency Limit: 66.5

At the bottom, there are buttons for 'Please Enter Password', 'Yes', 'Advanced Setting', and 'Cancel'.

### 10.3) Set the time: you can set the time for the device

The screenshot shows the 'Setting' menu with the following items:

- Time Slot 4: Load First, 04:01 ~ 05:00, Disable
- Time Slot 5: Battery First, 05:01 ~ 06:00, Enable
- Time Slot 6: Grid First, 06:01 ~ 23:00, Enable
- Set Inverter On/Off: Turn On
- Set Time**: 2024-06-13 16:30
- Grid recovery reconnection wait time: 0 (0~5000S)
- Mode Switch: Automatic
- High Grid Voltage Limit: 438.2 (17.3~762V)
- Low Grid Voltage Limit: 338.6 (17.3~762V)
- High Grid Frequency Limit: 66.5

At the bottom, there are buttons for 'Please Enter Password', 'Yes', 'Advanced Setting', and 'Cancel'.

10.4) Mode switch: you can choose to switch the working mode manually or automatically. If “Manual” is selected, you can set the device to operate in on-grid or off-grid or generator mode. Generally, you are advised to select “Automatic” mode switch.

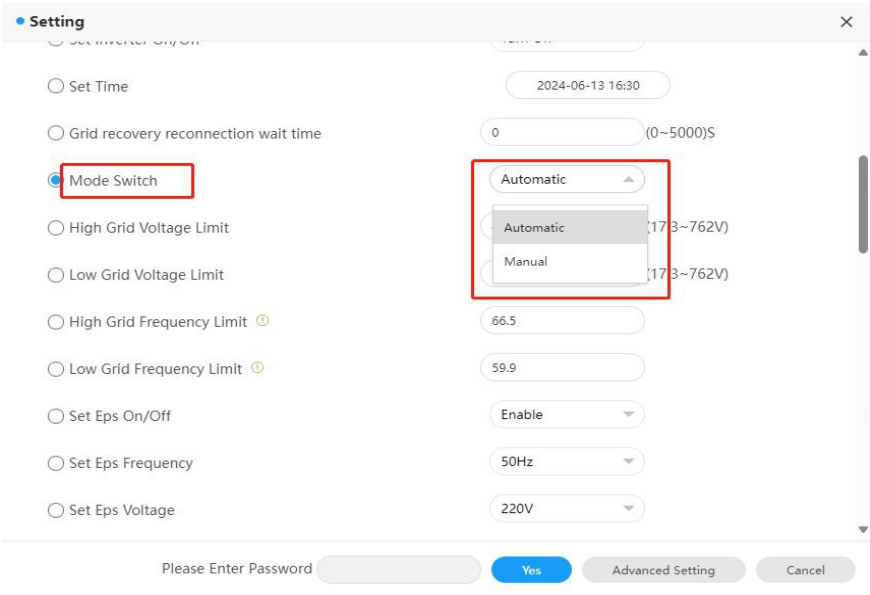

The screenshot shows a 'Setting' window with a list of configuration options. The 'Mode Switch' option is selected and highlighted with a red box. A dropdown menu is open for 'Mode Switch', showing three options: 'Automatic' (selected), 'Automatic (17.3~762V)', and 'Manual (17.3~762V)'. The 'Automatic' option is also highlighted with a red box. Other settings include 'Set Time' (2024-06-13 16:30), 'Grid recovery reconnection wait time' (0), 'High Grid Voltage Limit' (66.5), 'Low Grid Voltage Limit' (59.9), 'Set Eps On/Off' (Enable), 'Set Eps Frequency' (50Hz), and 'Set Eps Voltage' (220V). At the bottom, there is a 'Please Enter Password' field and buttons for 'Yes', 'Advanced Setting', and 'Cancel'.

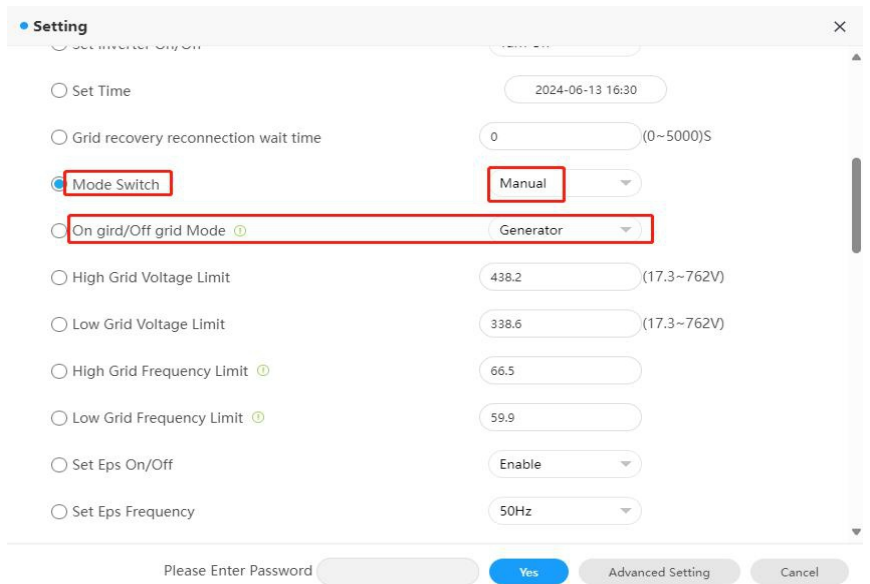

The screenshot shows the same 'Setting' window. The 'Mode Switch' option is now set to 'Manual' and is highlighted with a red box. The 'On grid/Off grid Mode' option is also highlighted with a red box and is set to 'Generator'. The other settings remain the same as in the previous screenshot. At the bottom, there is a 'Please Enter Password' field and buttons for 'Yes', 'Advanced Setting', and 'Cancel'.

### 10.5) High grid voltage limit (voltage upper threshold of grid connection)

Setting

Grid recovery/reconnection wait time

Mode Switch Manual

On grid/Off grid Mode Generator

High Grid Voltage Limit 438.2 (17.3~762V)

Low Grid Voltage Limit 338.6 (17.3~762V)

High Grid Frequency Limit 66.5

Low Grid Frequency Limit 59.9

Set Eps On/Off Enable

Set Eps Frequency 50Hz

Set Eps Voltage 220V

Set Save PF Command OFF

Please Enter Password

### 10.6) Low grid voltage limit (voltage lower threshold of grid connection)

Setting

Grid recovery/reconnection wait time

Mode Switch Manual

On grid/Off grid Mode Generator

High Grid Voltage Limit 438.2 (17.3~762V)

Low Grid Voltage Limit 338.6 (17.3~762V)

High Grid Frequency Limit 66.5

Low Grid Frequency Limit 59.9

Set Eps On/Off Enable

Set Eps Frequency 50Hz

Set Eps Voltage 220V

Set Save PF Command OFF

Please Enter Password

### 10.7) High grid frequency limit (frequency upper threshold of grid connection)

**Setting** ✕

Grid recovery reconnection wait time

Mode Switch Manual

On grid/Off grid Mode Generator

High Grid Voltage Limit 438.2 (17.3~762V)

Low Grid Voltage Limit 338.6 (17.3~762V)

High Grid Frequency Limit 66.5

Low Grid Frequency Limit 59.9

Set Eps On/Off Enable

Set Eps Frequency 50Hz

Set Eps Voltage 220V

Set Save PF Command OFF

Please Enter Password Yes Advanced Setting Cancel

### 10.8) Low grid frequency limit (frequency lower threshold of grid connection)

**Setting** ✕

Grid recovery reconnection wait time

Mode Switch Manual

On grid/Off grid Mode Generator

High Grid Voltage Limit 438.2 (17.3~762V)

Low Grid Voltage Limit 338.6 (17.3~762V)

High Grid Frequency Limit 66.5

Low Grid Frequency Limit 59.9

Set Eps On/Off Enable

Set Eps Frequency 50Hz

Set Eps Voltage 220V

Set Save PF Command OFF

Please Enter Password Yes Advanced Setting Cancel

### 10.9) Set off-grid mode on/off: you can set whether to operate the inverter in the off-grid mode

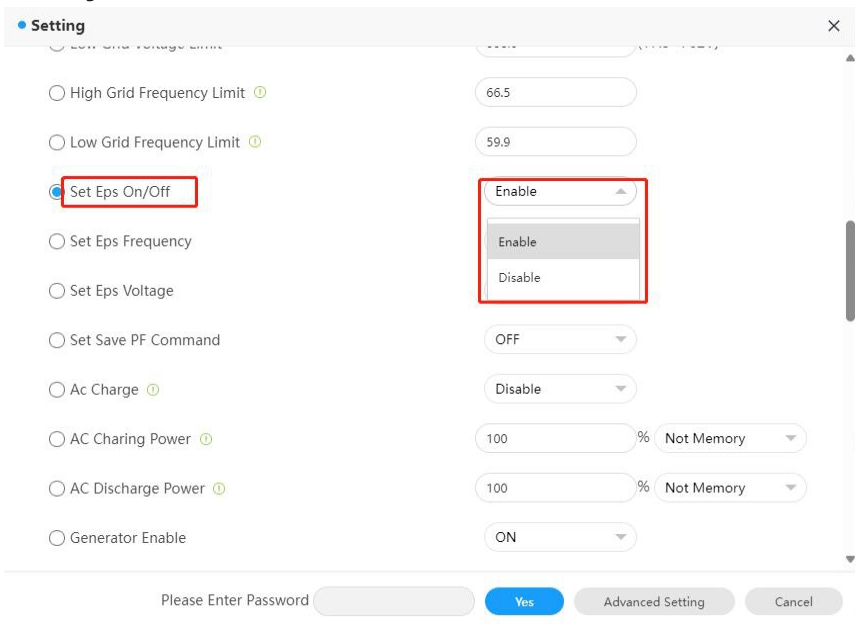

### 10.10) Off-grid frequency: two options are available: 50Hz/60Hz

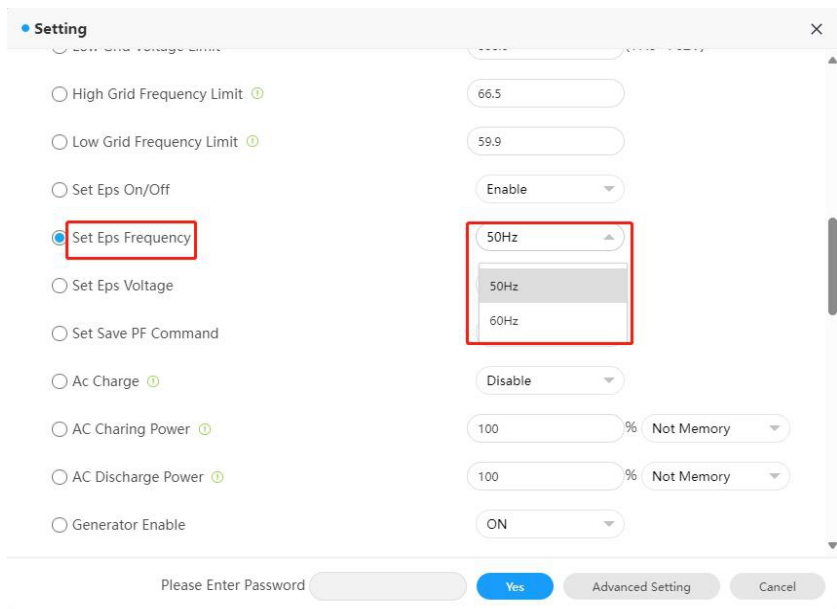

10.11) Off-grid voltage: you can set the value to 220V/230V

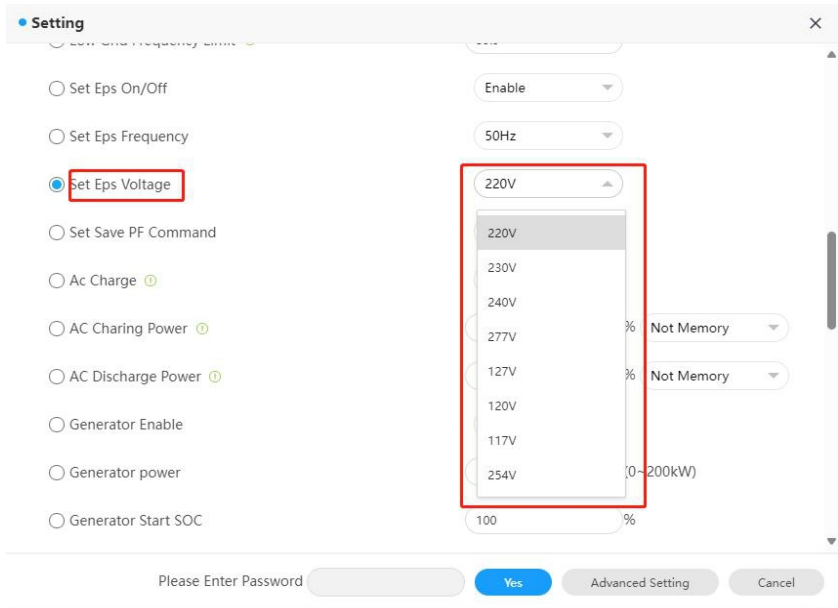

10.12) Save the PF Command: you can set whether to save the PF command setting

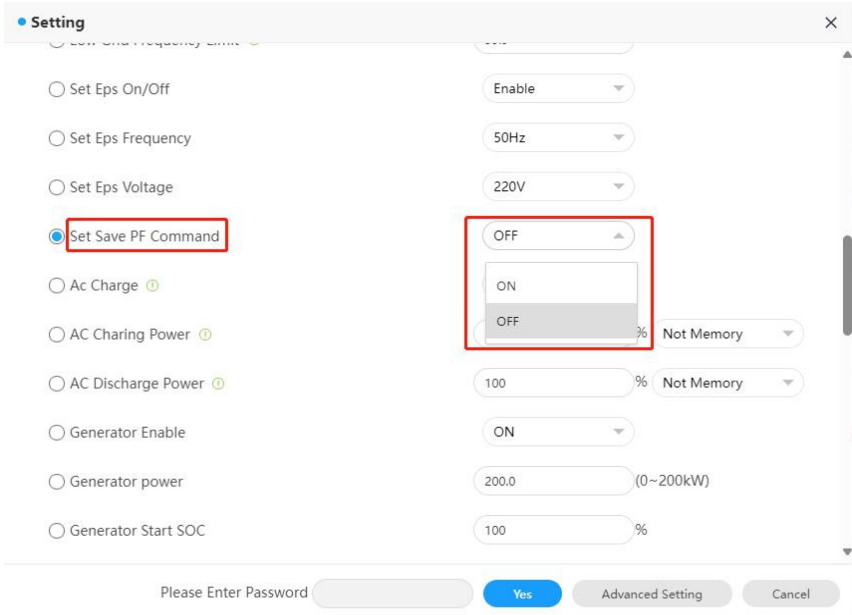

10.13) AC charging power: you can set the inverter's maximum output power

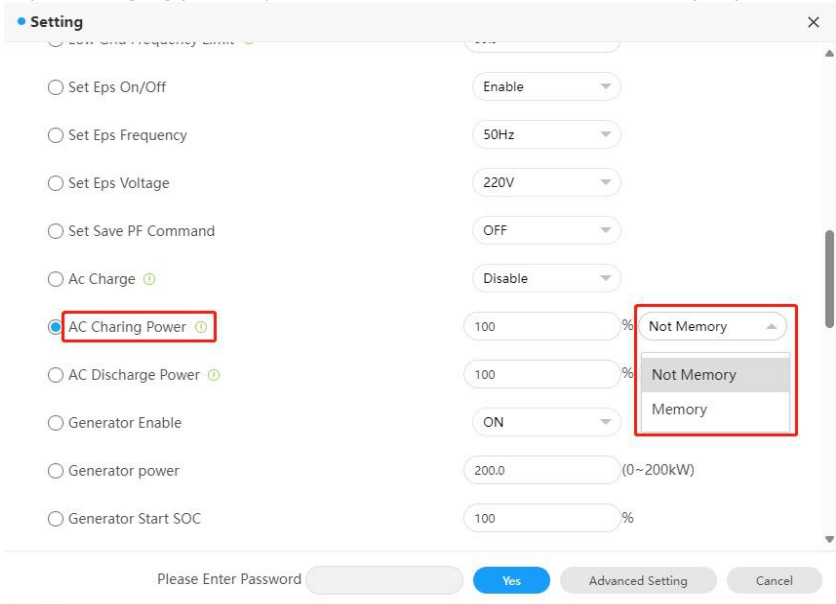

10.14) Charge cutoff SOC: you can set the battery charge cutoff SOC (100 is recommended)

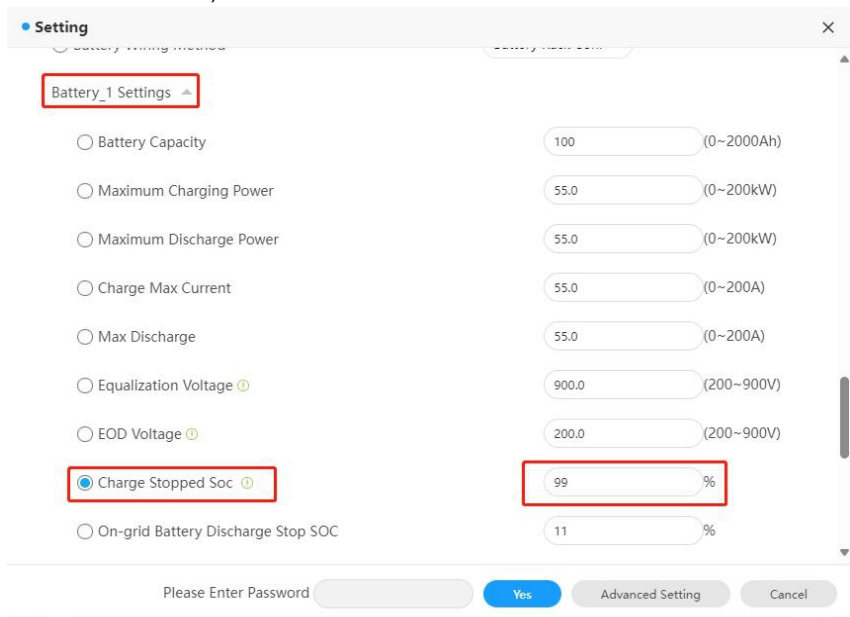

### 10.15) Enable AC charging:

**Setting** [X]

- Set Eps On/Off Enable
- Set Eps Frequency 50Hz
- Set Eps Voltage 220V
- Set Save PF Command OFF
- Ac Charge** Disable
- AC Charing Power 100 % Not Memory
- AC Discharge Power 100 % Not Memory
- Generator Enable ON
- Generator power 200.0 (0~200kW)
- Generator Start SOC 100 %

Please Enter Password

### 10.16) AC discharge power: you can set the battery discharge power

**Setting** [X]

- Set Eps Voltage 220V
- Set Save PF Command OFF
- Ac Charge Disable
- AC Charing Power 100 % Not Memory
- AC Discharge Power** 100 % Not Memory
- Generator Enable ON
- Generator power 200.0 (0~200kW)
- Generator Start SOC 100 %
- Generator Stop SOC 100 %
- Set Reactive Power Ratio 1.0 Set PF Not Memory
- Set PF Value 1.0 (-1~1)

Please Enter Password

10.17) Discharge cutoff SOC: you can set the battery discharge cutoff SOC (10 is recommended)

**Setting** [X]

Battery\_1 Settings [^]

- Battery Capacity: 100 (0~2000Ah)
- Maximum Charging Power: 55.0 (0~200kW)
- Maximum Discharge Power: 55.0 (0~200kW)
- Charge Max Current: 55.0 (0~200A)
- Max Discharge: 55.0 (0~200A)
- Equalization Voltage ⓘ: 900.0 (200~900V)
- EOD Voltage ⓘ: 200.0 (200~900V)
- Charge Stopped Soc ⓘ: 99 %
- On-grid Battery Discharge Stop SOC: 11 %
- Off-grid Battery Discharge Stop SOC: 0 %

Please Enter Password [ ] [Yes] [Advanced Setting] [Cancel]

10.18) Generator Start SOC: once the battery SOC is lower than this value, the generator will start up automatically

**Setting** [X]

- Ac Charge ⓘ: Disable [v]
- AC Charging Power ⓘ: 100 % [Not Memory [v]]
- AC Discharge Power ⓘ: 100 % [Not Memory [v]]
- Generator Enable: ON [v]
- Generator power: 200.0 (0~200kW)
- Generator Start SOC: 100 %
- Generator Stop SOC: 100 %
- Set Reactive Power Ratio: 1.0 [Set PF [v]] [Not Memory [v]]
- Set PF Value: 1.0 (-1~1)
- Set Exportlimit ⓘ: OFF [v] 100.0 [Limit Power Rate(%)]
- SingleExport ⓘ: OFF [v]

Please Enter Password [ ] [Yes] [Advanced Setting] [Cancel]

10.19) Generator Stop SOC: once the battery SOC is higher than this value, the generator will shut down

The screenshot shows a 'Setting' window with a list of configuration options. The 'Generator Stop SOC' option is selected with a blue radio button and its value is set to 100%. A red rectangular box highlights the 'Generator Stop SOC' label and its corresponding value field. At the bottom of the window, there is a 'Please Enter Password' field and three buttons: 'Yes' (highlighted in blue), 'Advanced Setting', and 'Cancel'.

Setting	Value
AC Discharge Power	100 %
Generator Enable	ON
Generator power	200.0 (0~200kW)
Generator Start SOC	100 %
<b>Generator Stop SOC</b>	<b>100 %</b>
Set Reactive Power Ratio	1.0 Set PF Not Memory
Set PF Value	1.0 (-1~1)
Set Exportlimit	OFF 100.0 Limit Power Rate(%)
SingleExport	OFF
Ext AC Inverter	On
Ext.PV Inverter Start SOC	100 %

10.20) Generator Enable: you can select to enable/disable the generator

The screenshot shows the 'Setting' window with the 'Generator Enable' option selected. A red rectangular box highlights the 'Generator Enable' label and its dropdown menu, which is currently open and shows 'ON' as the selected option. Other settings are visible in the background. At the bottom, there is a 'Please Enter Password' field and three buttons: 'Yes' (highlighted in blue), 'Advanced Setting', and 'Cancel'.

Setting	Value
Ac Charge	Disable
AC Charging Power	100 %
AC Discharge Power	100 %
<b>Generator Enable</b>	<b>ON</b>
Generator power	200.0 (0~200kW)
Generator Start SOC	100 %
Generator Stop SOC	100 %
Set Reactive Power Ratio	1.0 Set PF Not Memory
Set PF Value	1.0 (-1~1)
Set Exportlimit	OFF 100.0 Limit Power Rate(%)
SingleExport	OFF

10.21) Set Reactive Power: you can set the corresponding PF mode and select whether to save the configured values

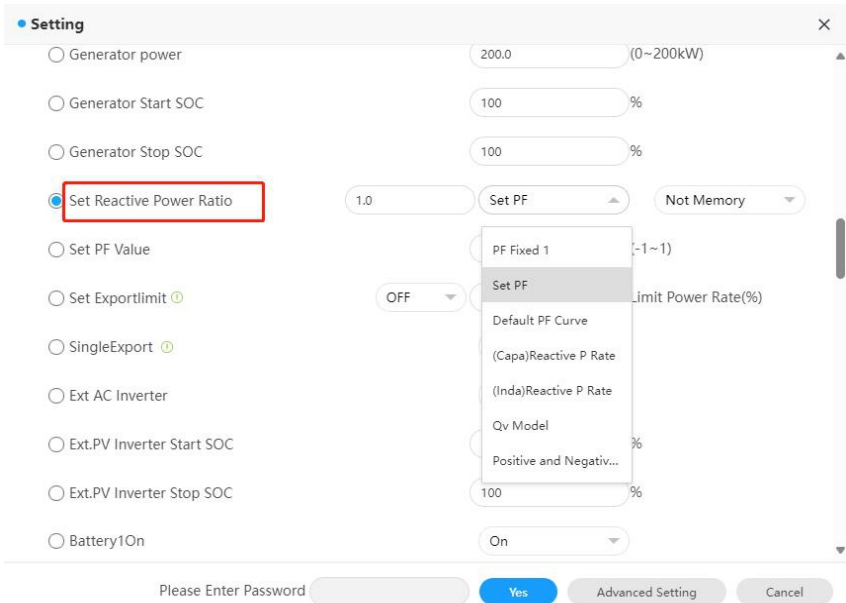

10.22) Export Limitation: You can enable/disable the export limitation function according to the local applicable regulations and set the export limit power rate if it is enabled

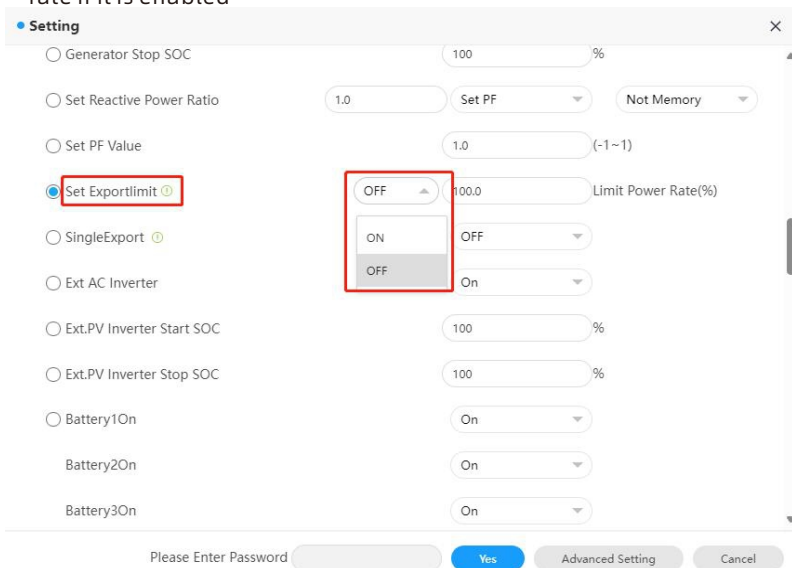

### 10.23) Single-phase Export Enable

**Setting** [X]

- Generator Stop SOC  %
- Set Reactive Power Ratio  **Set PF**
- Set PF Value  (-1~1)
- Set Exportlimit   Limit Power Rate(%)
- SingleExport**
- Ext AC Inverter
- Ext.PV Inverter Start SOC  %
- Ext.PV Inverter Stop SOC  %
- Battery1On
- Battery2On
- Battery3On

Please Enter Password

### 10.24) Set PF value: you can set the PF value, ranging from -1 to 1.

**Setting** [X]

- Generator power  (0~200kW)
- Generator Start SOC  %
- Generator Stop SOC  %
- Set Reactive Power Ratio  **Set PF**
- Set PF Value**  (-1~1)
- Set Exportlimit   Limit Power Rate(%)
- SingleExport
- Ext AC Inverter
- Ext.PV Inverter Start SOC  %
- Ext.PV Inverter Stop SOC  %
- Battery1On

Please Enter Password

10.25) Generator Power: you can set the generator power

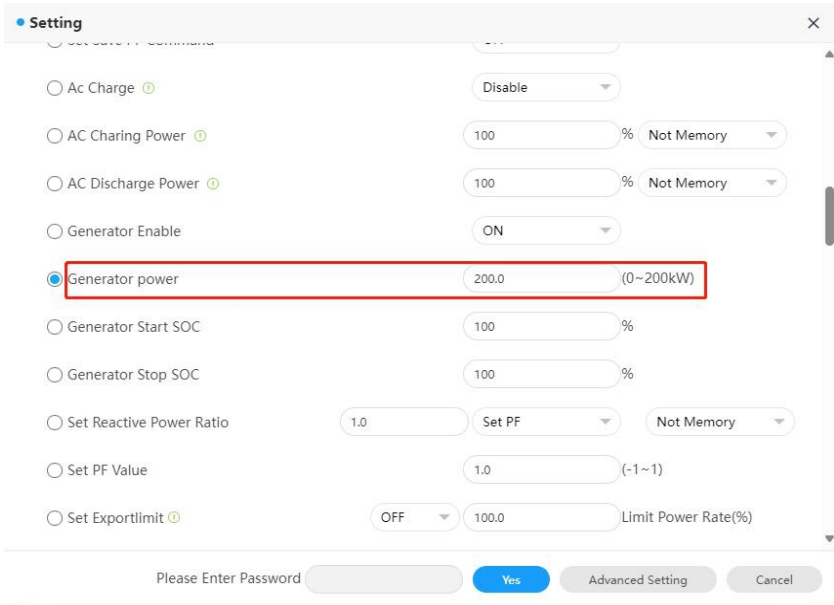

10.26) Battery Wiring Method: you can set the wiring between the inverter and the battery: three battery clusters are connected to the three ports respectively, or one battery cluster is connected to the three ports.

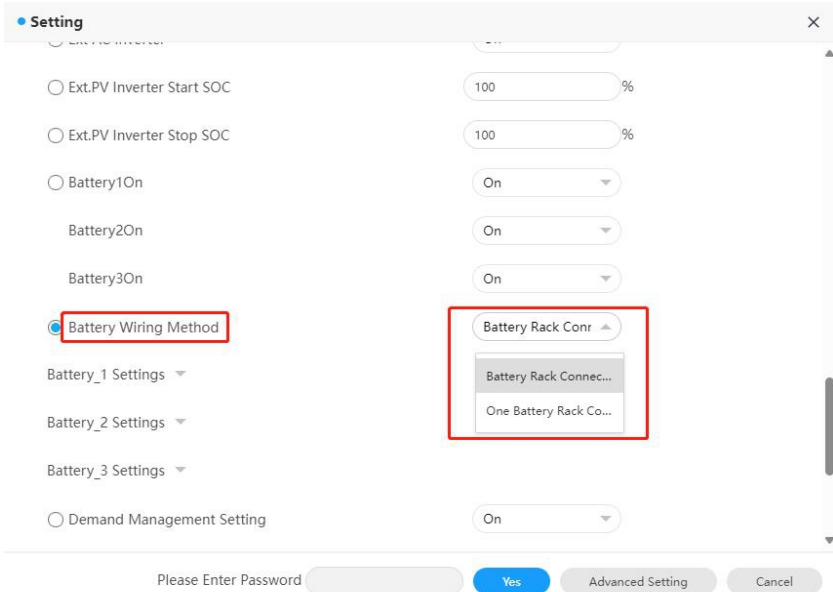

10.27) Externally connected PV inverter Start SOC: you can set the Externally connected PV inverter Starts SOC

The screenshot shows a 'Setting' dialog box with a close button (X) in the top right corner. The dialog contains several configuration options, each with a radio button and a corresponding control element (text input, dropdown, or range selector). The option 'Externally connected PV inverter Start SOC' is selected and highlighted with a red rectangular box. The value for this option is '100 %'. Other options include 'Set PF Value' (1.0), 'Set Exportlimit' (OFF, 100.0), 'SingleExport' (OFF), 'Externally connected PV inverter' (On), 'Externally connected PV inverter Stop SOC' (100 %), 'Battery1On' (On), 'Battery2On' (On), 'Battery3On' (On), and 'Battery Wiring Method' (Battery Rack Contr). At the bottom of the dialog, there is a 'Please Enter Password' field, a 'Yes' button, an 'Advanced Setting' button, and a 'Cancel' button.

10.28) Externally connected PV inverter Stop SOC: you can set the Externally connected PV inverter Stops SOC

The screenshot shows a 'Setting' dialog box with a close button (X) in the top right corner. The dialog contains several configuration options, each with a radio button and a corresponding control element. The option 'Externally connected PV inverter Stop SOC' is selected and highlighted with a red rectangular box. The value for this option is '100 %'. Other options include 'Set PF Value' (1.0), 'Set Exportlimit' (OFF, 100.0), 'SingleExport' (OFF), 'Externally connected PV inverter' (On), 'Externally connected PV inverter Start SOC' (100 %), 'Battery1On' (On), 'Battery2On' (On), 'Battery3On' (On), and 'Battery Wiring Method' (Battery Rack Contr). At the bottom of the dialog, there is a 'Please Enter Password' field, a 'Yes' button, an 'Advanced Setting' button, and a 'Cancel' button.

10.29) Externally connected PV inverter on: you can select whether to on the Externally connected PV inverter

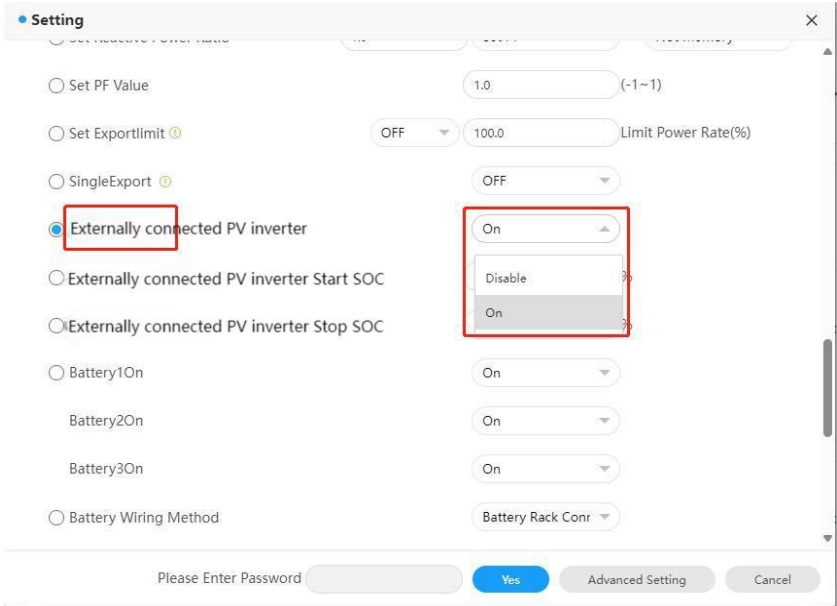

10.30) Battery1/2/3 On: you can select to enable/disable the Battery1/2/3

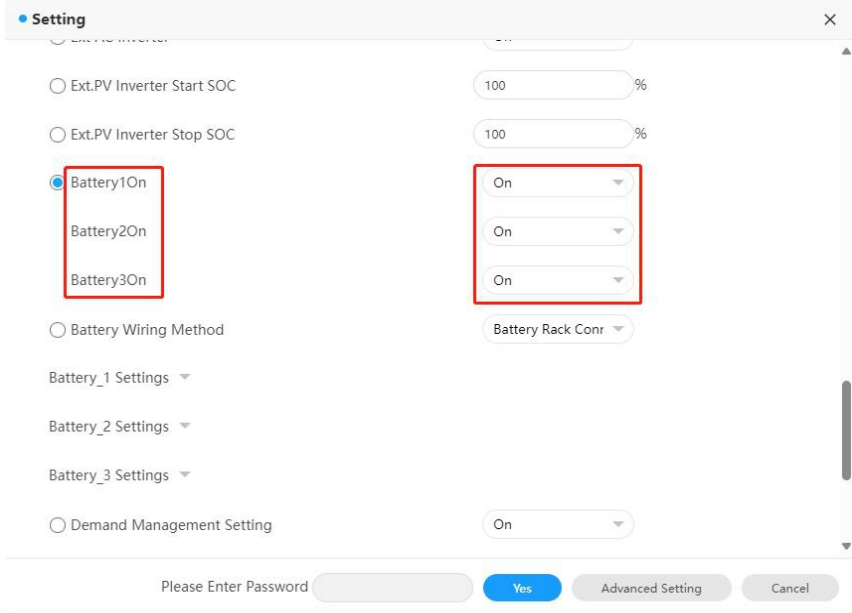

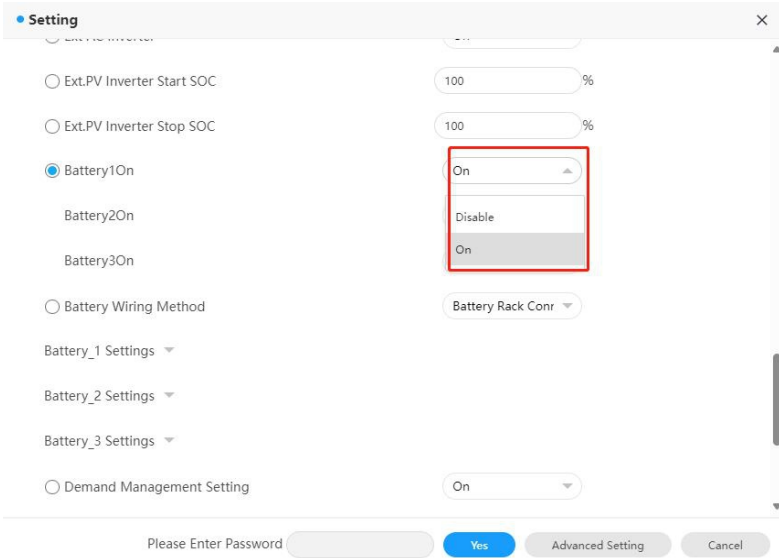

10.31) Battery\_1/2/3 Settings: you can set Battery-related parameters, including the battery capacity, ranging from 0 to 2000 Ah; the maximum charging/discharging power, ranging from 0 to 200 kW; the maximum charging/discharging current, ranging from 0 to 200A; the maximum battery charging voltage, ranging from 200V to 900V; and the battery discharge cutoff voltage, ranging from 200 V to 900V.

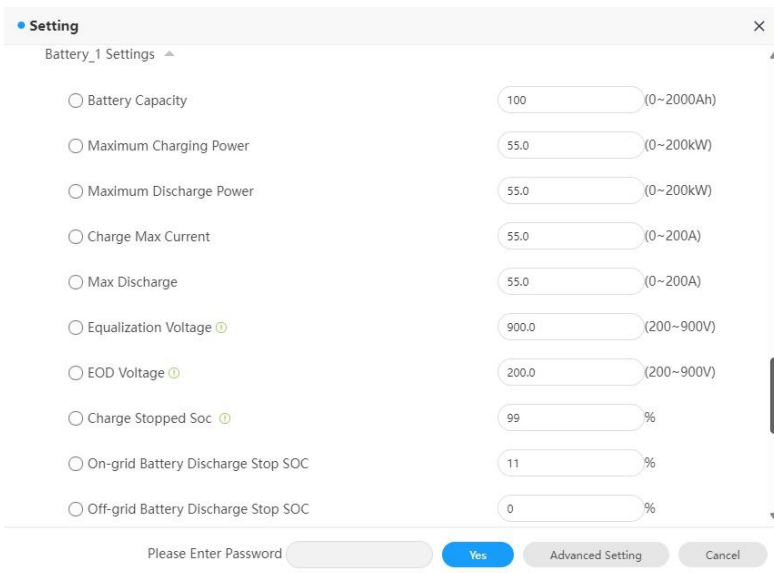



# System Maintenance 9



## 9.1 Routine Maintenance

### 9.1.1 Clean the Chassis

 <p><b>DANGER</b></p>	<ul style="list-style-type: none"><li>• Before performing any operation, disconnect the AC and DC power supply and wait for 5 minutes after the system is powered off.</li><li>• Wipe the dust off the chassis and clean the chassis with a moistened cloth.</li></ul>
--	--

- 1) Check periodically that the humidity is within the acceptable range and keep it away from dust;
- 2) Check the ventilation and heat dissipation of the equipment regularly. For details, see Section 9.1.2.

### 9.1.2 Fan Maintenance

 <p><b>DANGER</b></p>	<ul style="list-style-type: none"><li>• Only qualified and trained electrical technicians are allowed to perform operations. Technicians must observe instructions in this manual and comply with local regulations.</li><li>• Before performing any operation, disconnect all power supplies and wait for 5 minutes until the residual voltage is completely discharged.</li></ul>
 <p><b>WARNING</b></p>	<ul style="list-style-type: none"><li>• Do not use the air pump to clean the fan. Otherwise, the fan may be damaged.</li></ul>

Ventilation and heat dissipation is essential to protect the WIT Inverter from performance de-rate due to excess heat. The fan in the WIT Inverter works to cool the components and the heat sink when the temperature is too high. Check the following possible causes and measures when an exception occurs:

- 1> The fan is stuck with foreign objects or there is dust accumulation on the heat sink; clean the fan cover, fan blades and the heat sink.
- 2> The fan is damaged and needs to be replaced.

The installation position of the WIT Inverter is not well-ventilated. Select an appropriate installation position that meets the basic installation requirements.

#### **Cleaning and replacing the fan:**

- 1> Before cleaning or replacing a fan, disconnect the DC and AC power supply and wait for at least 5 minutes.
- 2> Remove the fan fixing plate using a cross-head screwdriver, as shown in Fig 9.1:

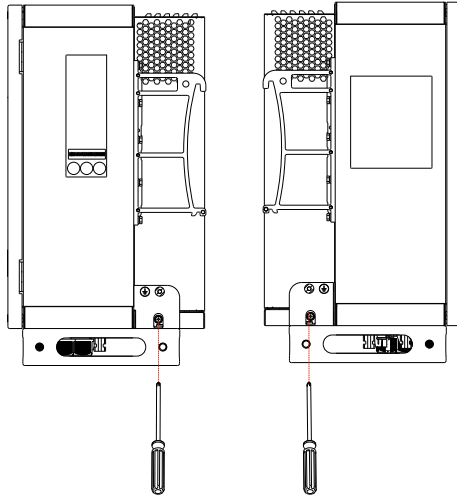

Fig 9.1

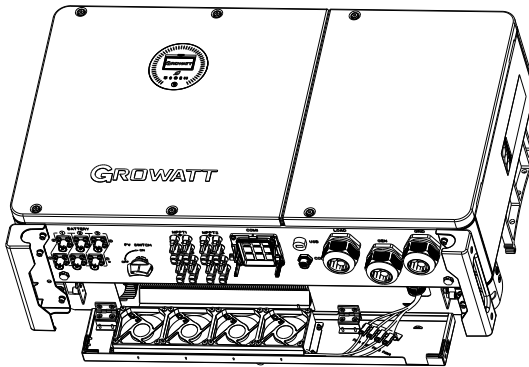

Fig 9.2 Position of the fan fixing plate

3> Disconnect the fan connector, remove the fan fixing plate with a screwdriver, and remove the fan.

4> Clean the fan cover, fan blades, and the heat sink, or replace the fan.

(1) Use an air pump to clean the heat sink, and use a brush or wet cloth to clean the fan and the its cover;

(2) Remove the fan for cleaning if necessary;

(3) Remove the fan that needs to be replaced using a cross-head screwdriver and install a new fan.

(4) Bind the cables and fix them with a cable tie.

(5) Reinstall the fan, the fan fixing plate, and the WIT Inverter.

## 9.2 Troubleshooting



**DANGER**

- It must be operated by trained and professional electrical technicians. Technicians must observe instructions in this manual and local regulations.
- If the WIT Inverter reports the “PV Isolation low” alarm, do not touch the equipment as a ground fault might have occurred.
- Beware of high voltages which can cause electric shocks.

### 9.2.1 Warning

Warnings indicate abnormal situations of WIT 29.9-50K-XHU Hybrid Inverters, leading to a reduction in the output power. The warning sign will disappear once the fault is rectified by restarting the inverter or reconfiguring the system. The warning codes are shown in Table 9.1:

Table 9.1 Warning codes

Warning	Description	Suggestion
Warning 200	String fault	<ol style="list-style-type: none"> <li>1. Check if the PV panels are normal after shutdown.</li> <li>2. If the error message persists, contact Growatt support.</li> </ol>
Warning 201	PV string/PID quick-connect terminals abnormal	<ol style="list-style-type: none"> <li>1. Check the wiring of the string terminals after shutdown.</li> <li>2. If the error message persists, contact Growatt support.</li> </ol>
DC SPD Warning	DC SPD function abnormal	<ol style="list-style-type: none"> <li>1. Check the DC SPD after shutdown.</li> <li>2. If the error message persists, contact Growatt support.</li> </ol>
Warning 203	PV1 or PV2 short circuited	<ol style="list-style-type: none"> <li>1. Check if PV1 or PV2 is short circuited.</li> <li>2. If the error message persists, contact Growatt support.</li> </ol>
Boost Warning	PV Boost driver abnormal	<ol style="list-style-type: none"> <li>1. Restart the inverter.</li> <li>2. If the error message persists, contact Growatt support.</li> </ol>
AC SPD Warning	AC SPD function abnormal	<ol style="list-style-type: none"> <li>1. After shutdown, check the AC SPD.</li> <li>2. If the fault persists, contact Growatt.</li> </ol>
Warning 208	DC fuse blows	<ol style="list-style-type: none"> <li>1. Power off the system and check the fuse.</li> <li>2. If the fault persists, contact Growatt.</li> </ol>

Warning	Description	Suggestion
Warning 209	DC input voltage exceeds the upper threshold	<ol style="list-style-type: none"> <li>1. Turn off the DC switch immediately and check the DC voltage.</li> <li>2. If the DC voltage is within the specified range and the error message persists, contact Growatt support.</li> </ol>
PV Reversed	PV string is reversely connected	<ol style="list-style-type: none"> <li>1. Check the polarity of the PV terminals.</li> <li>2. If the error message persists, contact Growatt support.</li> </ol>
Warning 219	PID function abnormal	<ol style="list-style-type: none"> <li>1. Restart the inverter.</li> <li>2. If the error message persists, contact Growatt support.</li> </ol>
Warning 220	PV string disconnected	<ol style="list-style-type: none"> <li>1. Check if the PV string is properly connected.</li> <li>2. If the error message persists, contact Growatt support.</li> </ol>
Warning 221	PV string current unbalanced	<ol style="list-style-type: none"> <li>1. Check if the PV panels of the corresponding string are normal.</li> <li>2. If the error message persists, contact Growatt support.</li> </ol>
Warning 300	No utility grid connected or utility grid power failure	<ol style="list-style-type: none"> <li>1. Check if the grid is down.</li> <li>2. If the error message persists, contact Growatt support.</li> </ol>
Warning 301	Grid voltage is beyond the permissible range	<ol style="list-style-type: none"> <li>1. Check if the grid voltage is within the specified range.</li> <li>2. If the error message persists, contact Growatt support.</li> </ol>
Warning 302	Grid frequency is beyond the permissible range	<ol style="list-style-type: none"> <li>1. Check if the grid frequency is within the specified range.</li> <li>2. If the error message persists, contact Growatt support.</li> </ol>
Warning 303	Overload	<ol style="list-style-type: none"> <li>1. Please reduce the load connected to the EPS output terminal.</li> <li>2. If the error message persists, contact Growatt support.</li> </ol>
Warning 308	Meter disconnected	<ol style="list-style-type: none"> <li>1. Check if the meter is properly connected.</li> <li>2. If the error message persists, contact Growatt support.</li> </ol>

Warning	Description	Suggestion
Warning 309	Meter is reversely connected	<ol style="list-style-type: none"> <li>1. Check if the L line and the N line of the meter are reversely connected.</li> <li>2. If the error message persists, contact Growatt support.</li> </ol>
Warning 310	The voltage difference between the N line and the PE cable is abnormal	<ol style="list-style-type: none"> <li>1. Check if the PE cable is reliably connected after shutdown.</li> <li>2. If the error message persists, contact Growatt support.</li> </ol>
Warning 311	Phase sequence error	No operation is required. The PCS will automatically adjust the phase sequence.
Warning 400	Fan failure	<ol style="list-style-type: none"> <li>1. Check if the fan is properly connected after shutdown.</li> <li>2. If the error message persists, contact Growatt support.</li> </ol>
Warning 401	Meter abnormal	<ol style="list-style-type: none"> <li>1. Check if the meter is turned on.</li> <li>2. If the meter is correctly connected to the inverter.</li> </ol>
Warning 402	Communication between the optimizer and the inverter is abnormal	<ol style="list-style-type: none"> <li>1. Check if the optimizer is turned on.</li> <li>2. If the optimizer is correctly connected to the inverter.</li> </ol>
Warning 407	Over-temperature	<ol style="list-style-type: none"> <li>1. Restart the inverter.</li> <li>2. If the error message persists, contact Growatt support.</li> </ol>
Warning 408	NTC temperature sensor is broken	<ol style="list-style-type: none"> <li>1. Restart the inverter.</li> <li>2. If the error message persists, contact Growatt support.</li> </ol>
Warning 411	Sync signal abnormal	<ol style="list-style-type: none"> <li>1. Check if the sync cable is abnormal.</li> <li>2. If the error message persists, contact Growatt support.</li> </ol>
Warning 412	Startup requirements of grid connection are not met	<ol style="list-style-type: none"> <li>1. Check if the grid voltage is within the specified range and check if the grid-connection startup voltage configuration is correct.</li> <li>2. Check if the PV voltage is within the specified range.</li> <li>3. Restart the inverter. If the error message persists, contact Growatt support.</li> </ol>

Warning	Description	Suggestion
Warning 500	The inverter failed to communicate with the battery	<ol style="list-style-type: none"> <li>1. Check if the battery is turned on.</li> <li>2. Check if the battery is correctly and securely connected to the inverter.</li> </ol>
Warning 501	Battery disconnected	<ol style="list-style-type: none"> <li>1. Check if the battery is properly connected.</li> <li>2. If the error message persists, contact Growatt support.</li> </ol>
Warning 502	Battery voltage too high	<ol style="list-style-type: none"> <li>1. Check if the battery voltage is within the permissible range.</li> <li>2. Check if the battery is correctly connected.</li> <li>3. If the error message persists, contact Growatt support.</li> </ol>
Warning 503	Battery voltage too low	<ol style="list-style-type: none"> <li>1. Check if the battery voltage is within the permissible range.</li> <li>2. Check if the battery is correctly connected.</li> <li>3. If the error message persists, contact Growatt support.</li> </ol>
Warning 504	Battery terminals are reversely connected	<ol style="list-style-type: none"> <li>1. Check if the positive and negative terminals of the battery are reversely connected.</li> <li>2. If the error message persists, contact Growatt support.</li> </ol>
Warning 505	Temperature sensor of the lead-acid battery is disconnected	<ol style="list-style-type: none"> <li>1. Check if the temperature sensor of the lead-acid battery is installed or not.</li> <li>2. Check if the temperature sensor is well-connected.</li> <li>3. If the error message persists, contact Growatt support.</li> </ol>
Warning 506	Battery temperature is out of range	<ol style="list-style-type: none"> <li>1. Check if the ambient temperature of the battery is within the specified range.</li> <li>2. If the error message persists, contact Growatt support.</li> </ol>
Warning 507	BMS reported a fault; both charging and discharging failed	<ol style="list-style-type: none"> <li>1. Figure out the cause according to the BMS error code.</li> <li>2. If the error message persists, contact Growatt support.</li> </ol>

Warning	Description	Suggestion
Warning 508	Lithium battery overload protection	<ol style="list-style-type: none"> <li>1. Check if the power of the load exceeds the BAT rated discharge power.</li> <li>2. If the error message persists, contact Growatt support.</li> </ol>
Warning 509	BMS communication abnormal	<ol style="list-style-type: none"> <li>1. Restart the inverter.</li> <li>2. If the error message persists, contact Growatt support.</li> </ol>
Warning 510	BAT SPD function abnormal	<ol style="list-style-type: none"> <li>1. Check the BAT SPD after powering off the device.</li> <li>2. If the error message persists, contact Growatt support.</li> </ol>
Warning 601	DC component over high in output voltage	<ol style="list-style-type: none"> <li>1. Restart the inverter.</li> <li>2. If the error message persists, contact Growatt support.</li> </ol>
Warning 605	Off-grid bus voltage too low	<ol style="list-style-type: none"> <li>1. Check if the load power exceeds the upper limit.</li> <li>2. Restart the inverter. If the error message persists, contact Growatt support.</li> </ol>
Warning 609	Balanced circuit abnormal	<ol style="list-style-type: none"> <li>1. Restart the inverter.</li> <li>2. If the error message persists, contact Growatt support.</li> </ol>

### 9.2.2 Error

The error code indicates that the device is damaged or the configurations are abnormal. Only qualified and trained electrical technicians are allowed to rectify the faults. The error message will disappear after the fault is rectified. If the problem persists, please contact Growatt.

Table 9.2 Error codes

Error Code	Description	Suggestion
AFCI Fault	An arc fault has been detected	<ol style="list-style-type: none"> <li>1. After shutdown, check the connection of the PV string.</li> <li>2. Restart the inverter.</li> <li>3. If the error message persists, please contact Growatt support.</li> </ol>
GFCI High	An excessively high leakage current has been detected	<ol style="list-style-type: none"> <li>1. Restart the inverter.</li> <li>2. If the error message persists, please contact Growatt support.</li> </ol>
PV Voltage High	DC input voltage exceeds the upper threshold	<ol style="list-style-type: none"> <li>1. Disconnect the DC switch immediately and check the voltage.</li> <li>2. If the DC input voltage is within the permissible range and the error message persists, please contact Growatt support.</li> </ol>
PV Isolation Low	PV panels have low insulation resistance	<ol style="list-style-type: none"> <li>1. Check if the PV strings are properly grounded.</li> <li>2. If the error message persists, please contact Growatt support.</li> </ol>
PV Reversed	PV string reversely connected	<ol style="list-style-type: none"> <li>1. After shutdown, check if the PV string is reversely connected to the inverter.</li> <li>2. Restart the inverter.</li> <li>3. If the error message persists, please contact Growatt support.</li> </ol>
AC V Outrange	Grid voltage is beyond the permissible range	<ol style="list-style-type: none"> <li>1. Check the grid voltage.</li> <li>2. If the grid voltage is within the permissible range and the error message persists, please contact Growatt support.</li> </ol>
No AC	No utility grid connected or utility grid power failure	<ol style="list-style-type: none"> <li>1. After shutdown, check the AC wiring.</li> <li>2. If the error message persists, please contact Growatt support.</li> </ol>

<b>Error Code</b>	<b>Description</b>	<b>Suggestion</b>
NE Abnormal	The voltage difference between the N line and the PE cable is abnormal	1. After shutdown, check if the ground cable is reliably connected. 2. If the error message persists, please contact Growatt support.
AC F Outrange	Grid frequency is beyond the permissible range	1. Check the grid frequency and restart the inverter. 2. If the error message persists, please contact Growatt support.
Error 309	Grid ROCOF (Rated of Change of Frequency) abnormal	1. Check the grid frequency and restart the inverter. 2. If the error message persists, please contact Growatt support.
NE Fault	Neutral-to-Ground voltage is too low	1. Check whether the N line on the inverter side with PV negative grounding is short-circuited with the ground cable and whether the output side is isolated with a transformer. 2. If the error message persists, please contact Growatt support.
Error 311	Export limitation fail-safe	1. After shutdown, check the connection of the CT and the meter. 2. If the error message persists, please contact Growatt support.
Error 400	DCI bias abnormal	1. Restart the inverter. 2. If the error message persists, contact Growatt support.
Error 402	High DC component in output current	1. Restart the inverter. 2. If the error message persists, contact Growatt support.
Error 404	Bus voltage sampling abnormal	1. Restart the inverter. 2. If the error message persists, please contact Growatt support.
Error 405	Relay fault	1. Restart the inverter. 2. If the error message persists, please contact Growatt support.
Error 408	Over-temperature	1. After shutdown, check the temperature of the inverter and restart the inverter after the temperature is within the acceptable range. 2. If the error message persists, please contact Growatt support.

<b>Error Code</b>	<b>Description</b>	<b>Suggestion</b>
Error 409	Bus voltage abnormal	1. Restart the inverter. 2. If the error message persists, please contact Growatt support.
Error 411	Internal communication failure	1. Check the wiring of the communication board after shutdown. 2. If the error message persists, please contact Growatt support.
Error 412	Temperature sensor disconnected	1. Check if the temperature sensor module is properly connected. 2. If the error message persists, please contact Growatt support.
Error 413	IGBT drive fault	1. Restart the inverter. 2. If the error message persists, please contact Growatt support.
Error 414	EEPROM error	1. Restart the inverter. 2. If the error message persists, please contact Growatt support.
Error 415	Auxiliary power supply abnormal	1. Restart the inverter. 2. If the error message persists, please contact Growatt support.
Error 416	DC/AC overcurrent protection	1. Restart the inverter. 2. If the error message persists, please contact Growatt support.
Error 417	Communication protocol mismatch	1. Restart the inverter. 2. If the error message persists, please contact Growatt support.
Error 418	DSP and COM firmware version mismatch	1. Check the firmware version. 2. If the error message persists, please contact Growatt support.
Error 419	DSP software and hardware version mismatch	1. Check the firmware version. 2. If the error message persists, please contact Growatt support.
Error 421	CPLD abnormal	1. Restart the inverter. 2. If the error message persists, please contact Growatt support.
Error 422	Redundancy sampling inconsistent	1. Restart the inverter. 2. If the error message persists, please contact Growatt support.
Error 423	PWM pass-through signal failure	1. Restart the inverter. 2. If the error message persists, please contact Growatt support.

<b>Error Code</b>	<b>Description</b>	<b>Suggestion</b>
Error 425	AFCI self-test failure	<ol style="list-style-type: none"> <li>1. Restart the inverter.</li> <li>2. If the error message persists, please contact Growatt support.</li> </ol>
Error 426	PV current sampling abnormal	<ol style="list-style-type: none"> <li>1. Restart the inverter.</li> <li>2. If the error message persists, please contact Growatt support.</li> </ol>
Error 427	AC current sampling abnormal	<ol style="list-style-type: none"> <li>1. Restart the inverter.</li> <li>2. If the error message persists, please contact Growatt support.</li> </ol>
Error 430	EPO fault	<ol style="list-style-type: none"> <li>1. Restart the inverter.</li> <li>2. If the error message persists, please contact Growatt support.</li> </ol>
Error 431	Monitoring chip BOOT verification failed	<ol style="list-style-type: none"> <li>1. Restart the inverter.</li> <li>2. If the error message persists, please contact Growatt support.</li> </ol>
Error 500	BMS failed to communicate with the inverter	<ol style="list-style-type: none"> <li>1. Check the connection of the RS485 cable between the inverter and the battery.</li> <li>2. Check if the battery is in the sleep mode.</li> <li>3. If the error message persists, please contact Growatt support.</li> </ol>
Error 501	The BMS reports that the battery failed to charge/discharge	<ol style="list-style-type: none"> <li>1. Figure out the fault based on the BMS error code.</li> <li>2. If the error message persists, please contact Growatt support.</li> </ol>
Bat Voltage Low	The battery voltage is below the lower threshold	<ol style="list-style-type: none"> <li>1. Check the battery voltage.</li> <li>2. If the error message persists, please contact Growatt support.</li> </ol>
Error 503	The battery voltage exceeds upper threshold	<ol style="list-style-type: none"> <li>1. Check the battery voltage. If it is within the permissible range, please restart the inverter. If not, please replace the battery.</li> <li>2. If the error message persists, please contact Growatt support.</li> </ol>
Error 504	The battery temperature is beyond the range for charging / discharging	<ol style="list-style-type: none"> <li>1. Check the temperature of the battery.</li> <li>2. If the error message persists, please contact Growatt support.</li> </ol>

<b>Error Code</b>	<b>Description</b>	<b>Suggestion</b>
Bat Reversed	Battery terminals reversed	<ol style="list-style-type: none"> <li>1. Check if the battery terminals are reversely connected.</li> <li>2. If the error message persists, please contact Growatt support.</li> </ol>
Error 506	Battery open-circuited	<ol style="list-style-type: none"> <li>1. Check the wiring of the battery terminals.</li> <li>2. If the error message persists, please contact Growatt support.</li> </ol>
Error 507	Battery overload protection	<ol style="list-style-type: none"> <li>1. Check if the power of the load exceeds the battery rated discharge power.</li> <li>2. If the error message persists, please contact Growatt support.</li> </ol>
Error 508	BUS2 Volt Abnormal	<ol style="list-style-type: none"> <li>1. Restart the inverter.</li> <li>2. If the error message persists, please contact Growatt support.</li> </ol>
Error 509	BAT Charge OCP (Overcurrent Protection)	<ol style="list-style-type: none"> <li>1. Check if the PV voltage is oversized.</li> <li>2. If the error message persists, please contact Growatt support.</li> </ol>
Error 510	BAT Discharge OCP (Overcurrent Protection)	<ol style="list-style-type: none"> <li>1. Check if the battery discharge current configuration is proper.</li> <li>2. If the error message persists, please contact Growatt support.</li> </ol>
Error 511	BAT soft start failed	<ol style="list-style-type: none"> <li>1. Restart the inverter.</li> <li>2. If the error message persists, please contact Growatt support.</li> </ol>
EPS Output Short	Off-grid output short-circuited	<ol style="list-style-type: none"> <li>1. Restart the inverter.</li> <li>2. If the error message persists, please contact Growatt support.</li> </ol>
Error 601	Off-grid BUS Volt Low	<ol style="list-style-type: none"> <li>1. Check if the battery is working properly or the battery experiences capacity loss.</li> <li>2. If the error message persists, please contact Growatt support.</li> </ol>
Error 602	Abnormal Volt at the off-grid terminal	<ol style="list-style-type: none"> <li>1. Check if a voltage is present at the AC port.</li> <li>2. If the error message persists, please contact Growatt support.</li> </ol>

<b>Error Code</b>	<b>Description</b>	<b>Suggestion</b>
Error 603	Soft start failed	1. Restart the inverter. 2. If the error message persists, please contact Growatt support.
Error 604	Off-grid output voltage abnormal	1. Restart the inverter. 2. If the error message persists, please contact Growatt support.
Error 605	Balanced circuit self-test failed	1. Restart the inverter. 2. If the error message persists, please contact Growatt support.
Error 606	High DC component in output voltage	1. Restart the inverter. 2. If the error message persists, please contact Growatt support.
EPS Overload	Off-grid output overload	1. Restart the inverter. 2. If the error message persists, please contact Growatt support.
Error 608	Off-grid parallel signal abnormal	1. Check if the communication cables are properly connected. 2. If the error message persists, please contact Growatt support.

# 10 Product Specifications

Table 10.1 WIT 29.9/30/36/40/50K-XHU specification

Model	WIT 29.9K -XHU	WIT 30K -XHU	WIT 36K -XHU	WIT 40K -XHU	WIT 50K -XHU
<b>Specifications</b>					
Input data(PV)					
Max. recommended PV power(for module STC)	59.8kW	60kW	72kW	80kW	100kW
Max. DC voltage	1100V				
Start voltage	195V				
Nominal voltage	620V				
MPP voltage range	180V-1000V				
Full Load DC Voltage Range	375V-850V	375V-850V	450V-850V	500V-850V	620V-850V
No. of MPP trackers	4				
No. of PV strings per MPP tracker	2				
Max. input current per MPP tracker	40A				
Max. short-circuit current per MPP tracker	50A				
<b>Battery data (DC)</b>					
Battery voltage range	200-900V				
Full load battery voltage range	200V-800V	200V-800V	225V-800V	250V-800V	310V-800V
Recommended battery voltage	512V				
No. of battery input	3				
Max. charging / discharging current	55A*3				
BMS communication	RS485/CAN				
<b>Input/Output AC(GRID)</b>					
AC input/output nominal power	59.8KW/ 29.9KW	60KW/ 30KW	72KW/ 36KW	80KW/ 40KW	100KW/ 50KW
Max. AC input/output apparent power	59.8KVA /29.9KVA	66KVA/ 33KVA	79.2KVA/ 39.6KVA	88KVA/ 44KVA	110KVA/ 55KVA
Nominal AC voltage/range	380V/400V -15%~10%				

Model Specifications	WIT 29.9K -XHU	WIT 30K -XHU	WIT 36K -XHU	WIT 40K -XHU	WIT 50K -XHU
Nominal AC grid frequency/range	50Hz/60Hz 45-55Hz/55-65Hz				
Max. input/output current	90.6A/ 45.3A@220V	100A/ 50A@220V	120A/ 60A@220V	133.3A/ 66.7A@220V	166.7A/ 83.3A@220V
Max. Continuous AC Passthrough	200A				
Power factor (@nominal power)	>0.99				
Adjustable power factor	-1...+1				
THDi	<3% @100% load <5% @30%/60%/100% load				
AC grid connection type	3P3W+PE/3P4W+PE				
Input/Output Generator (GEN)					
AC nominal power	59.8KW/ 29.9KW	60KW/ 30KW	72KW/ 36KW	80KW/ 40KW	100KW/ 50KW
Max. input current(GEN/AC Couple)	90.6A/ 45.3A	100A/ 45.5A	120A/ 54.5A	133.3A/ 60.7A	166.7A/ 75.7A
Max.Continuous AC Passthrough	200A				
Nominal AC voltage	380V/400V				
Nominal AC grid frequency	50Hz/60Hz				
AC connection type	3P3W+PE/3P4W+PE				
Stand alone(Back up)					
AC nominal output power	29.9KW	30KW	36KW	40KW	50KW
Max. AC apparent power	29.9KVA	45KVA	54KVA	60KVA	75KVA
Nominal AC voltage	220V/230V(L-N) 380V/400V(L-L)				
Nominal AC frequency	50/60HZ				
Max. output current	68.0A	68.2A	81.8A	91A	113.6A
Overload Capability	1.5 time of rated power, 10 S				
THDv	<3% (Linear full load)				

Model	WIT 29.9K -XHU	WIT 30K -XHU	WIT 36K -XHU	WIT 40K -XHU	WIT 50K -XHU
Switch time	≤10ms				
Efficiency					
Max. efficiency	98.10%				
European efficiency	97.2%				
Protection devices					
DC reverse polarity protection	Yes				
Battery reverse protection	Yes				
Insulation resistance monitoring	Yes				
AC/DC surge protection	Type II				
AC short-circuit protection	Yes				
Ground fault monitoring	Yes				
Grid monitoring	Yes				
String monitoring	Yes				
Anti-islanding protection	Yes				
Residual-current monitoring unit	Yes				
PID function	Optional				
AFCI protection	Optional				
General data					
Dimensions (W / H / D)	920/585/320mm				
Weight	92kg				
Operating temperature range	-30°C - 60°C (>50°C, derating)				
Noise emission (typical)	≤55dB				
Altitude	4000m				
Topology	Transformerless				
Cooling	Smart air cooling				

<b>Model</b>	<b>WIT 29.9K -XHU</b>	<b>WIT 30K -XHU</b>	<b>WIT 36K -XHU</b>	<b>WIT 40K -XHU</b>	<b>WIT 50K -XHU</b>
<b>Specifications</b>					
Protection degree	IP66				
Relative humidity	0~95%				
PV connection	MC4				
AC connection	Cable gland +SC terminal				
Battery connection	Quick connection plug				
<b>Interfaces</b>					
Display	OLED+LED/APP				
RS485/CAN/USB	RS485/CAN/USB				
WIFI/4G/LAN	WIFI/LAN				
Warranty: 5 / 10 years	Yes/Opt.				
<b>Certificates and approvals</b>					
Grid regulation	NRS 097-2-1:2017, EN50549-1, NC RFG, PSE-2018, PTPIREE-2021, IEC62116, IEC61727, G99:2020,VDE 4105				
EMC	IEC/EN61000-6-1, IEC/EN61000-6-3				
Safety	IEC/EN62109-1, IEC/EN62109-2, IEC/EN62477-1				

# 11 Decommissioning the WIT Inverter

Handle the WIT Inverter that will not be operated in the future properly.

- 1> Disconnect the external AC circuit breaker and prevent accidental reconnection due to improper operation.
- 2> Set the DC switches to the OFF position.
- 3> Disconnect the upstream battery circuit breaker.
- 4> Wait at least 5 minutes before performing operations on it.
- 5> Disconnect the AC output power cables.
- 6> Disconnect the DC input power cables.
- 7> Remove the inverter from the bracket.
- 8> Dispose of the inverter according to local disposal rules.

# Warranty 12

Growatt guarantees maintenance and replacement of the defective product under warranty.

## 12.1 Conditions

1. Growatt will ask users to provide product information by filling a form before making warranty repairs, including the date of purchase and installation, the serial number of the WIT Inverter, fault description and other information.
2. The defected product shall be returned to Growatt for recycling and disposal.

## 12.2 Disclaimer

Growatt shall not be liable for any consequences of the following circumstances:

1. Unauthorized removal of the product, such as removing the tamper-proof label and the upper cover of the WIT Inverter.
  2. Damage caused during transportation.
  3. Improper operations during installation and commissioning.
  4. Failure to observe the operation instructions regarding the installation, operation and storage of the WIT Inverter.
  5. Unauthorized modifications or improper maintenance on the WIT Inverter.
  6. Improper use and operation.
  7. Damage caused by storage conditions that do not meet the requirements specified in this manual.
  8. Failure to follow the safety precautions and applicable laws and regulations due to customer's negligence.
  9. Damage due to force majeure, such as lightning, floods, storms, fire.
  10. Power off the PCS before upgrading the firmware; otherwise it will shut down automatically during the upgrade process and supply no power to the loads.
- In the event of a product malfunction or failure caused by the circumstance mentioned above, Growatt can provide paid maintenance services after conducting a fault diagnosis if required.

# 13 Contact Us

If you have technical problems with our products, please contact Growatt for technical support. To provide you with the necessary assistance, please have the following information ready:

1. Model number of the WIT Inverter
2. Serial number of the WIT Inverter
3. Error code of the WIT Inverter
4. Information indicated on the LED display
5. DC input voltage and AC output voltage of the WIT Inverter
6. Communication method of the WIT Inverter

Shenzhen Growatt New Energy Co., Ltd.

4-13/F, Building A, Sino-German (Europe) Industrial Park,  
Hangcheng Blvd, Bao'an District, Shenzhen, China

**T** +86 755 2747 1942

**E** [service@ginverter.com](mailto:service@ginverter.com)

**W** [en.growatt.com](http://en.growatt.com)



Download  
Manual



Growatt New Energy

Shenzhen Growatt New Energy Co., Ltd.

4-13/F, Building A, Sino-German (Europe) Industrial Park,  
Hangcheng Blvd, Bao'an District, Shenzhen, China

**T** +86 755 2747 1942

**E** [service@ginverter.com](mailto:service@ginverter.com)

**W** [en.growatt.com](http://en.growatt.com)

GR-UM-419-A-01 (PN: 044.0131801)